

AN OVERVIEW ON SPECTRAL THEORY FOR NONLINEAR OPERATORS

ALESSANDRO CALAMAI¹, MASSIMO FURI², AND ALFONSO VIGNOLI³

¹Dipartimento di Scienze Matematiche, Università Politecnica delle Marche,
I-60131 Ancona, Italy
E-mail: calamai@dipmat.univpm.it

²Dipartimento di Matematica Applicata “G. Sansone”, Università di Firenze,
I-50139 Firenze, Italy
E-mail: massimo.furi@unifi.it

³Dipartimento di Matematica, Università di Roma “Tor Vergata”,
I-00133 Roma, Italy
E-mail: vignoli@mat.uniroma2.it

Dedicated to Prof. Espedito de Pascale on the occasion of his retirement

ABSTRACT. We compare different spectral theories for nonlinear operators, focusing in particular on the notion of spectrum at a point recently introduced by the authors. We discuss the main properties of the nonlinear spectrum and present illustrating applications and examples.

AMS (MOS) Subject Classification. 47J10, 47H14, 47J05.

1. INTRODUCTION

The purpose of this paper is to compare different notions of spectra for nonlinear maps. In particular we will focus on the *spectrum at a point* recently introduced by the authors (see [9]). Related works on nonlinear spectral theory are due to Appell [1] and Appell, De Pascale and Vignoli [2]. As a basic reference we cite the monograph [3].

In view of the importance of spectral theory for linear operators, it is not surprising that several efforts have been made to define and study spectra in the nonlinear context. A reasonable definition of spectrum of a continuous nonlinear operator should satisfy some basic requirements: first it should reduce to the familiar spectrum in case of linear operators. Moreover, it should possibly share some of the classical properties with the linear spectrum. Finally, it should have nontrivial applications. Unfortunately, it turns out that, when building a nonlinear spectral theory, one is led to several “unpleasant” phenomena. First of all, in contrast to the linear case, the

spectrum of a nonlinear operator contains little information on the operator itself. Moreover, the familiar properties such as boundedness, closedness, or nonemptiness fail, in general, for all the spectra proposed so far in the literature. In this paper we will discuss spectra for various classes of nonlinear operators and compare their properties from the viewpoint of the above requirements.

First we will consider a spectrum for continuous operators due to Rhodius [24], and a spectrum for C^1 operators which goes back to Neuberger [23]. The Rhodius spectrum may be noncompact or empty, while the Neuberger spectrum is always nonempty (in the complex case), but it need be neither closed nor bounded. Then we take into account a spectrum for Lipschitz continuous operators which was first proposed by Kachurovskij in 1969 (see [19]). Let us mention here also a spectrum for linearly bounded operators introduced recently by Dörfner in [10] (see also [2]). In contrast to the Neuberger spectrum, the Kachurovskij spectrum is compact, but it may be empty even in (complex) dimension 2. All these spectra reduce to the classical spectrum in the linear case, and they all contain the eigenvalues of the operator involved (i.e. those λ for which $f(x) = \lambda x$ for some $x \neq 0$). Interestingly, these spectra always contain 0 in the case of a compact operator in an infinite dimensional Banach space. This is of course completely analogous to the linear case.

Then we consider the spectrum introduced in [13] by Furi, Martelli, and Vignoli, called *FuMaVi* (or *asymptotic*) *spectrum* for short, which is defined for any continuous map from a Banach space into itself. Roughly speaking, one may say that this spectrum takes into account the asymptotic properties of an operator. This spectrum is always closed, sometimes even bounded, and coincides with the classical spectrum in the linear case. A different and related notion of spectrum has been introduced by Feng in 1997 (see [11]). The Feng spectrum is related to the global behavior of an operator, has similar topological properties as the FuMaVi spectrum and contains all the eigenvalues. However, the computation of the eigenvalues requires the knowledge of the operator in the whole space. A very interesting approach to some kind of local spectrum is due to Văth (see e.g. [27]). Since his construction is rather far from what one usually calls a spectrum, it has been called *phantom*. There are several other spectra for nonlinear operators in the literature which deserve being quoted here. For instance the Infante–Webb spectrum [18] and the Appell–Giorgieri–Văth spectrum [5].

Recently, a new definition of spectrum has been proposed by the authors in [9]. Given an open subset U of a Banach space E , a continuous map $f : U \rightarrow E$, and a point $p \in U$, they introduce the concept of *spectrum of f at p* , which is denoted by $\sigma(f, p)$. This spectrum is close in spirit to the FuMaVi spectrum. Nevertheless, while the asymptotic spectrum is related to the asymptotic behavior of a map, $\sigma(f, p)$ depends only on the germ of f at p ; that is, the equivalence class of maps which

coincide with f in some neighborhood of p . We stress that the first attempt to introduce a notion of spectrum at a point was undertaken by E.L. May in [22] by means of a suitable local adaptation of Neuberger's ideas. In 1977 the last two authors gave another definition of spectrum at a point (see [16]). Given f and p as above, they define a spectrum $\Sigma(f, p)$ which, in the case of a bounded linear operator $L : E \rightarrow E$, gives only a part of the classical spectrum $\sigma(L)$. Namely, $\Sigma(L, p)$ reduces to the approximate point spectrum of L . Therefore, the definition of $\Sigma(f, p)$ is somehow nonexhaustive and the new spectrum at a point $\sigma(f, p)$, in some sense, fills the gap. The crucial notions in the new definition of spectrum at a point are the topological concept of *zero-epi map* (see [14]) as well as two numerical characteristics recently introduced by the first author in [7] (see also [8]). These notions are briefly recalled in Section 6.

Concerning the topological properties of our spectrum at a point, we show that $\sigma(f, p)$ is always closed and contains $\Sigma(f, p)$. Moreover, in the case of a positively homogeneous map $f : E \rightarrow E$, the spectrum $\sigma(f, 0)$ at 0 coincides with the asymptotic spectrum of f , and for a bounded linear operator L , we get $\sigma(L, p) = \sigma(L)$ for any $p \in E$, where $\sigma(L)$ is the classical spectrum of L . More precisely, if a map f is C^1 , then $\sigma(f, p)$ equals the spectrum of the Fréchet derivative $\sigma(f'(p))$. Thus, in the complex case, the spectrum at a point of a C^1 map is always nonempty, as the Neuberger spectrum. The spectrum at a point turns out to be useful to tackle bifurcation problems in the non-differentiable case. This paper closes with a few examples illustrating some peculiarities of this spectrum, and some applications to bifurcation theory.

Notation. Throughout the paper, E and F will be two Banach spaces over \mathbb{K} , where \mathbb{K} is \mathbb{R} or \mathbb{C} . Given a subset X of E , by $C(X, F)$ we denote the set of all continuous maps from X into F . By I we denote the identity on E . Given a subset A of a metric space X , \bar{A} , $\text{Int } A$ and ∂A stand for the closure, the interior and the boundary of A , respectively. In the sequel we will adopt the conventions $\sup \emptyset = -\infty$ and $\inf \emptyset = +\infty$, so that if $A \subseteq B \subseteq \mathbb{R}$, then $\inf A \geq \inf B$ and $\sup A \leq \sup B$ even when A is empty.

Let $f : X \rightarrow Y$ be a continuous map between two metric spaces. We recall that f is said to be *compact* if $f(X)$ is relatively compact, and *completely continuous* if it is compact on any bounded subset of X . If for any $p \in X$ there exists a neighborhood V of p such that the restriction $f|_V$ is compact, then f is called *locally compact*. By a standard abuse of terminology, a locally compact linear operator between Banach spaces is said to be *compact*. The map f is said to be *proper* if $f^{-1}(K)$ is compact for any compact subset K of Y . Recall that a proper map sends closed sets into closed

sets. Given $p \in X$, f is *locally proper at p* if there exists a closed neighborhood V of p such that the restriction $f|_V$ is proper.

2. THE RHODIUS, NEUBERGER AND KACHUROVSKIJ SPECTRA

The Rhodius spectrum. In [24], A. Rhodius proposed a naive definition of spectrum that runs as follows. Given a continuous map $f : E \rightarrow E$ such that $f(0) = 0$, the set

$$\rho_R(f) = \{\lambda \in \mathbb{K} : \lambda I - f \text{ is bijective and } (\lambda I - f)^{-1} \text{ continuous}\}$$

is called the *Rhodius resolvent set* and its complement $\sigma_R(f) = \mathbb{K} \setminus \rho_R(f)$ the *Rhodius spectrum* of f . Thus, a point $\lambda \in \mathbb{K}$ belongs to $\rho_R(f)$ if and only if $\lambda I - f$ is a homeomorphism on E .

Notice that in the case of a bounded linear operator this gives the definition of the classical spectrum. One could expect that at least some of the properties of the linear spectrum carry over to the Rhodius spectrum. This is not true even for the most elementary properties. We illustrate this fact with a series of simple examples which we will further use in the sequel.

Example 2.1. Let $E = \mathbb{R}$ and $f(x) = x^n$ with $n \in \mathbb{N}$, $n \geq 2$. Then, $\sigma_R(f) = \mathbb{R}$ if n is even and $\sigma_R(f) = (0, \infty)$ if n is odd. On the other hand, let $E = \mathbb{C}$ and $f(z) = z^n$ with $n \in \mathbb{N}$, $n \geq 2$. Then, $\sigma_R(f) = \mathbb{C}$ for any n . Thus, the Rhodius spectrum is, in general, neither closed nor bounded.

Example 2.2. Let $E = \mathbb{R}$ and $f(x) = \arctan x$. Then, $\sigma_R(f) = [0, 1)$.

Example 2.3. Let $E = \mathbb{C}^2$ and $f(z, w) = (\bar{w}, i\bar{z})$. Then, $\sigma_R(f) = \emptyset$ since, for any $\lambda \in \mathbb{C}$, the map $f_\lambda(z, w) = (\lambda z - \bar{w}, \lambda w - i\bar{z})$ is a homeomorphism on \mathbb{C}^2 with inverse

$$f_\lambda^{-1}(\zeta, \omega) = \left(\frac{\bar{\lambda}\zeta + \bar{\omega}}{i + |\lambda|^2}, -\frac{\bar{\lambda}\omega + i\bar{\zeta}}{i - |\lambda|^2} \right).$$

This last example, which was given in [17] in a different context, shows that the Rhodius spectrum may be empty.

The Neuberger spectrum. In [23], J. W. Neuberger proposed the following definition of spectrum. Given a map $f : E \rightarrow E$ of class C^1 such that $f(0) = 0$, the set

$$\rho_N(f) = \{\lambda \in \mathbb{K} : \lambda I - f \text{ is bijective and } (\lambda I - f)^{-1} \text{ of class } C^1\}$$

is called the *Neuberger resolvent set* and its complement $\sigma_N(f) = \mathbb{K} \setminus \rho_N(f)$ the *Neuberger spectrum* of f . Thus, a point $\lambda \in \mathbb{K}$ belongs to $\rho_N(f)$ if and only if $\lambda I - f$ is a diffeomorphism on E .

Again, this definition agrees with the classical one in the linear case. If f is of class C^1 , we have the trivial inclusion $\sigma_R(f) \subseteq \sigma_N(f)$.

Whenever possible, let us compute the Neuberger spectrum in the above examples. In Example 2.1 we have, in the case $E = \mathbb{R}$, $\sigma_N(f) = \mathbb{R}$ if n is even and $\sigma_N(f) = [0, \infty)$ if n is odd. In the case $E = \mathbb{C}$, we have again $\sigma_N(f) = \mathbb{C}$ for any n . Example 2.1 shows that the Neuberger spectrum need not be bounded. In Example 2.2 we have $\sigma_N(f) = [0, 1]$. On the other hand, Example 2.3 is not applicable, since the map given there is not differentiable at any point $(z, w) \in \mathbb{C}^2$. In fact, it turns out that the Neuberger spectrum shares the following important property with the linear spectrum.

Theorem 2.4 (Neuberger [23]). *The Neuberger spectrum of a C^1 map is always nonempty in the case $\mathbb{K} = \mathbb{C}$.*

Notice that the Neuberger spectrum need not be closed. This already happens in the one dimensional case, as it is shown by the following example.

Example 2.5. Consider the C^1 real function $f(x) = \log(1 + |x|) \operatorname{sign} x$. It is easy to check that $\sigma_N(f) = \sigma_R(f) = [0, 1)$.

Since the Neuberger spectrum is defined for C^1 operators, one should expect that it might be expressed through the linear spectra of the Fréchet derivatives. This is in fact true as shown in [4]. We recall the result given there.

Theorem 2.6 (Appell and Dörfner [4]). *Given $f : E \rightarrow E$ of class C^1 such that $f(0) = 0$, denote by $\pi(f)$ the set of all $\lambda \in \mathbb{K}$ such that the operator $\lambda I - f$ is not proper. Then*

$$\sigma_N(f) = \pi(f) \cup \bigcup_{x \in E} \sigma(f'(x)).$$

In particular, $\sigma_N(f) \neq \emptyset$ in case $\mathbb{K} = \mathbb{C}$.

Notice that if E is an infinite dimensional Banach space and $f : E \rightarrow E$ is completely continuous, then f cannot be proper. Thus, given a completely continuous map $f : E \rightarrow E$ of class C^1 , as a consequence of Theorem 2.6 one has $0 \in \pi(f) \subseteq \sigma_N(f)$. This is of course analogous to the case of a compact linear operator.

The Kachurovskij spectrum. We introduce now the following definition. We write $f \in \operatorname{Lip}(E)$ if f is *Lipschitz continuous* on E , i.e.

$$[f]_{\operatorname{Lip}} = \sup_{x \neq y} \frac{\|f(x) - f(y)\|}{\|x - y\|} < \infty.$$

Following [19], given a map $f : E \rightarrow E$ in the class $\operatorname{Lip}(E)$ such that $f(0) = 0$, the set

$$\rho_K(f) = \{\lambda \in \mathbb{K} : \lambda I - f \text{ is bijective and } (\lambda I - f)^{-1} \text{ belongs to } \operatorname{Lip}(E)\}$$

is called the *Kachurovskij resolvent set* and its complement $\sigma_K(f) = \mathbb{K} \setminus \rho_K(f)$ the *Kachurovskij spectrum* of f . Thus, a point $\lambda \in \mathbb{K}$ belongs to $\rho_K(f)$ if and only if $\lambda I - f$ is a lipeomorphism on E .

If f is in the class $Lip(E)$, we have the trivial inclusion $\sigma_R(f) \subseteq \sigma_K(f)$. Let us point out that the operator f_λ in Example 2.3 is a lipeomorphism for each $\lambda \in \mathbb{C}$. This shows that $\sigma_K(f) = \emptyset$ in this example.

The Kachurovskij spectrum possesses some nice properties, as the following result shows.

Theorem 2.7 (Maddox and Wickstead [21]). *The Kachurovskij spectrum, $\sigma_K(f)$, of a map $f \in Lip(E)$ is bounded and closed. Moreover the following inclusion holds:*

$$\sigma_K(f) \subseteq \{\lambda \in \mathbb{K} : |\lambda| \leq [f]_{Lip}\}.$$

Notice that for a bounded linear operator $L : E \rightarrow E$ we have $[L]_{Lip} = \|L\|$. Consequently, the above inclusion generalizes the known inequality between the spectral radius and the norm of a bounded linear operator.

Let us briefly check the other examples from the viewpoint of the Kachurovskij spectrum. Clearly, Example 2.1 does not apply. In Example 2.2 we have $\sigma_K(f) = [0, 1]$ and in Example 2.5 we have $\sigma_K(f) = [0, 1)$.

As we have seen, the Rhodius and Kachurovskij spectra may be empty. Nevertheless, the following result holds.

Theorem 2.8. *Assume that $\dim E = \infty$ and let $f : E \rightarrow E$ be completely continuous. Then, $0 \in \sigma_R(f)$. If, moreover, $f \in Lip(E)$, then $0 \in \sigma_K(f)$.*

The above theorem is analogous to a well known result for compact linear operators. Example 2.3 shows that the assumption $\dim E = \infty$ is essential.

3. THE ASYMPTOTIC FURI–MARTELLI–VIGNOLI SPECTRUM

In this section we recall the definition of spectrum for nonlinear operators introduced in 1978 by Furi, Martelli, and Vignoli. This spectrum is based on the notion of stable solvability of operators, a nonlinear analogue to surjectivity, and has found various applications to integral equations, boundary value problems, and bifurcation theory.

The definition of this spectrum requires some technical preliminary notions. First, let us recall the definition and properties of the Kuratowski measure of noncompactness (see [20]). The *Kuratowski measure of noncompactness* $\alpha(A)$ of a subset A of E is defined as the infimum of real numbers $d > 0$ such that A admits a finite covering by sets of diameter less than d . In particular, if A is unbounded, we have

$\alpha(A) = \inf \emptyset = +\infty$. Notice that, if E is finite dimensional, then $\alpha(A) = 0$ for any bounded subset A of E . Observe that $\alpha(A) = 0$ if and only if \overline{A} is compact.

Given a subset X of E and $f \in C(X, F)$, we recall the definition of the following two extended real numbers (see e.g. [13]) associated with the map f :

$$\alpha(f) = \sup \left\{ \frac{\alpha(f(A))}{\alpha(A)} : A \subseteq X \text{ bounded, } \alpha(A) > 0 \right\},$$

and

$$\omega(f) = \inf \left\{ \frac{\alpha(f(A))}{\alpha(A)} : A \subseteq X \text{ bounded, } \alpha(A) > 0 \right\}.$$

Notice that $\alpha(f) = -\infty$ and $\omega(f) = +\infty$ whenever E is finite dimensional.

It is important to observe that $\alpha(f) \leq 0$ if and only if f is completely continuous. Moreover, $\omega(f) > 0$ only if f is proper on bounded closed sets. For a comprehensive list of properties of $\alpha(f)$ and $\omega(f)$ we refer to [13].

Let $f \in C(E, F)$. We define the quasinorm of f as

$$|f| = \limsup_{\|x\| \rightarrow +\infty} \frac{\|f(x)\|}{\|x\|},$$

and the number

$$d(f) = \liminf_{\|x\| \rightarrow +\infty} \frac{\|f(x)\|}{\|x\|}.$$

We call f *quasibounded* if $|f| < \infty$. Assuming $f(0) = 0$, we have $|f| \leq [f]_{Lip}$ and $\alpha(f) \leq [f]_{Lip}$.

Following [12], we say that $f \in C(E, F)$ is *stably solvable* if for any compact map $h : E \rightarrow F$ such that $|h| = 0$, the equation $f(x) = h(x)$ has a solution in E .

Observe that every stably solvable operator is surjective, but in general the converse is not true. For linear operators, however, surjectivity is equivalent to stable solvability (see e.g. [12]).

We are now ready to define the FuMaVi spectrum. We need first to introduce the notion of FMV-regular map. A map f is said to be *FMV-regular* if it is stably solvable, $\omega(f) > 0$, and $d(f) > 0$. Observe that a bounded linear operator is FMV-regular if and only if it is an isomorphism.

The following stability property of FMV-regular maps can be regarded as a Rouché-type perturbation theorem.

Theorem 3.1 (Stability theorem for FMV-regular maps, [13]). *Assume that f is FMV-regular and let $g = f + k$, where $k \in C(E, F)$ is such that $\alpha(k) < \omega(f)$ and $|k| < d(f)$. Then g is FMV-regular.*

Let now $f \in C(E, E)$. We define the *asymptotic spectrum of the map f* as the set

$$\sigma_{FMV}(f) = \{\lambda \in \mathbb{K} : \lambda I - f \text{ is not FMV-regular}\}.$$

It is convenient to define the following subsets of $\sigma_{FMV}(f)$:

$$\begin{aligned}\sigma_{\omega,FMV}(f) &= \{\lambda \in \mathbb{K} : \omega(\lambda I - f) = 0\}, & \Sigma_{FMV}(f) &= \{\lambda \in \mathbb{K} : d(\lambda I - f) = 0\}, \\ \sigma_{\pi,FMV}(f) &= \sigma_{\omega,FMV}(f) \cup \Sigma_{FMV}(f),\end{aligned}$$

and

$$\sigma_{\delta,FMV}(f) = \{\lambda \in \mathbb{K} : \lambda I - f \text{ is not stably solvable}\}.$$

We shall call $\sigma_{\pi,FMV}(f)$ the *(asymptotic) approximate point spectrum of f* and $\sigma_{\delta,FMV}(f)$ the *(asymptotic) approximate defect spectrum of f* .

Note that for a bounded linear operator this gives the definition of the classical spectrum. More precisely, the following properties hold.

Theorem 3.2 ([13]). *Let $L : E \rightarrow E$ be a bounded linear operator. Then*

1. $\sigma_{FMV}(L)$ coincides with the classical spectrum of L ;
2. $\sigma_{\delta,FMV}(L)$ coincides with the classical approximate defect spectrum of L . In other words, $\lambda \in \sigma_{\delta,FMV}(L)$ if and only if $\lambda I - L$ is not onto;
3. $\sigma_{\pi,FMV}(L)$ coincides with the classical approximate point spectrum of L . In other words, $\lambda \in \sigma_{\pi,FMV}(L)$ if and only if $\inf_{\|x\|=1} \|\lambda x - Lx\| = 0$.

We are now ready to investigate the topological properties of the asymptotic spectrum. It is known that $\sigma_{FMV}(f) = \emptyset$ for the map f given in Example 2.3 (see [13]), and thus also the asymptotic spectrum may be empty.

The following result provides three nontrivial properties of the asymptotic spectrum.

Theorem 3.3 ([13]). *The following properties hold:*

1. $\sigma_{FMV}(f)$ is closed;
2. $\sigma_{\pi,FMV}(f)$ is closed;
3. $\partial\sigma_{FMV}(f) \subseteq \sigma_{\pi,FMV}(f)$.

The next result provides a sufficient condition for the boundedness of the asymptotic spectrum.

Theorem 3.4 ([13]). *Assume that f is quasibounded with $\alpha(f) < \infty$. Then $\sigma_{FMV}(f)$ is bounded. More precisely the following inclusion holds:*

$$\sigma_{FMV}(f) \subseteq \{\lambda \in \mathbb{K} : |\lambda| \leq \max\{\alpha(f), |f|\}\}.$$

Analogously to all the previous spectra, the following result holds.

Theorem 3.5 ([13]). *Assume that $\dim E = \infty$ and let $f : E \rightarrow E$ be completely continuous. Then, $0 \in \sigma_{FMV}(f)$.*

Let us briefly check the other examples from the viewpoint of the asymptotic spectrum. Consider Example 2.1. In the case $E = \mathbb{R}$, we have $\sigma_{FMV}(f) = \mathbb{R}$ if n is even and $\sigma_{FMV}(f) = \emptyset$ if n is odd. Using the Brower degree one could prove that in the case $E = \mathbb{C}$ one has $\sigma_{FMV}(f) = \emptyset$ for any $n \geq 2$. Both in Example 2.2 and in Example 2.5 we have $\sigma_{FMV}(f) = \{0\}$.

4. THE FENG SPECTRUM

In this section we discuss another notion of spectrum, due to Feng [11], which is similar to the FuMaVi spectrum and is meaningful only for maps vanishing at the origin, and preferably positively homogeneous.

Let $f \in C(E, F)$. We recall the definition of the following numerical characteristics associated with f :

$$M(f) = \sup_{\|x\| \neq 0} \frac{\|f(x)\|}{\|x\|} \quad \text{and} \quad m(f) = \inf_{\|x\| \neq 0} \frac{\|f(x)\|}{\|x\|}.$$

Assuming $f(0) = 0$, we have $m(f) \leq d(f) \leq |f| \leq M(f)$.

Now, let U be a bounded open subset of E , and $f \in C(\overline{U}, F)$. We need to recall the following definitions given in [14].

Definition 4.1. Given $y \in F$, we say that f is *y-admissible (on U)* if $f(x) \neq y$ for any $x \in \partial U$.

Definition 4.2. We say that f is *y-epi (on U)* if it is *y-admissible* and for any compact map $h : \overline{U} \rightarrow F$ such that $h(x) = y$ for all $x \in \partial U$ the equation $f(x) = h(x)$ has a solution in U .

Notice that f is *y-epi* if and only if the map $f - y$, defined by $(f - y)(x) = f(x) - y$, is 0-epi (zero-epi).

The main properties of zero-epi maps are analogous to some of the properties which characterize the Leray–Schauder degree. For a comprehensive list of properties of zero-epi maps we refer to [14]. In particular, we mention the following ones to be used in the sequel.

Proposition 4.3. *If $f \in C(U, F)$ is a local homeomorphism at p , then it is $f(p)$ -epi at p .*

Proposition 4.4 (Localization). *If $f \in C(\overline{U}, F)$ is 0-epi on U , and U_1 is an open subset of U containing $f^{-1}(0)$, then $f|_{\overline{U}_1}$ is 0-epi.*

The next local surjectivity property of zero-epi maps has been proved in [14].

Theorem 4.5 (Local surjectivity). *Let $f \in C(\overline{U}, F)$ be 0-epi on U and proper on \overline{U} . Then, f maps U onto a neighborhood of the origin. More precisely, if V is the connected component of $F \setminus f(\partial U)$ containing the origin, then $V \subseteq f(U)$.*

Given $r > 0$, by B_r we denote the open ball in E centered in the origin with radius r . Following [11], define by $\nu_r(f)$ the infimum of all $k > 0$ such that there exists a map $g \in C(\overline{B}_r, F)$ such that $g(x) = 0$ for all $x \in \partial B_r$, $\alpha(g) \leq k$, and $f(x) \neq g(x)$ for all $x \in B_r$. Then, the number

$$\nu(f) = \inf_{r>0} \nu_r(f)$$

is called the *measure of solvability* of f at 0.

Let us now introduce the notion of F-regular map. A map $f \in C(E, F)$ is said to be *F-regular* if $\omega(f) > 0$, $m(f) > 0$, and $\nu(f) > 0$. One can show that a bounded linear operator is F-regular if and only if it is an isomorphism. Thus, the following definition again extends the linear spectrum.

Let $f \in C(E, E)$ be such that $f(0) = 0$. We define the *Feng spectrum of the map* f as the set

$$\sigma_F(f) = \{\lambda \in \mathbb{K} : \lambda I - f \text{ is not F-regular}\}.$$

As all the other spectra considered above, we have that the Feng spectrum, $\sigma_F(f)$, is empty for the map f given in Example 2.3.

We observe that the Feng spectrum contains the asymptotic spectrum. Thus, as a consequence of Theorem 3.5, when $\dim E = \infty$, for a completely continuous map $f : E \rightarrow E$ we have $0 \in \sigma_F(f)$. Moreover, the Feng spectrum shares the following property with the asymptotic spectrum.

Theorem 4.6 (Feng [11]). *The spectrum $\sigma_F(f)$ is closed.*

A nice property of the Feng spectrum is to contain the nonlinear “eigenvalues”.

Theorem 4.7 (Feng [11]). *Let $\lambda \in \mathbb{K}$ be such that $f(x) = \lambda x$ for some $x \neq 0$. Then, $\lambda \in \sigma_F(f)$.*

The next result, which is analogous to Theorem 3.4, provides a sufficient condition for the Feng spectrum to be bounded.

Theorem 4.8 (Feng [11]). *Assume that f verifies $M(f) < \infty$ and $\alpha(f) < \infty$. Then $\sigma_F(f)$ is bounded. More precisely the following inclusion holds:*

$$\sigma_F(f) \subseteq \{\lambda \in \mathbb{K} : |\lambda| \leq \max\{\alpha(f), M(f)\}\}.$$

Let us briefly check the other examples from the viewpoint of the Feng spectrum. Consider Example 2.1. In the case $E = \mathbb{R}$, we have $\sigma_F(f) = \mathbb{R}$ if n is even and $\sigma_F(f) = [0, \infty)$ if n is odd. On the other hand, in the case $E = \mathbb{C}$ we have $\sigma_F(f) = \mathbb{C}$ for any n . This example shows that the Feng spectrum may be unbounded. Both in Example 2.2 and in Example 2.5 we have $\sigma_F(f) = [0, 1]$.

5. THE VÄTH PHANTOM

In this section we discuss two spectra which have been recently introduced by Väth under the name “phantoms” (see [25], [26], [27], [28]). The definition is based on a topological notion which is similar to the concept of zero-epi map.

Let $U \subseteq E$ be open, bounded, connected and containing 0, and let $f \in C(\overline{U}, F)$. Following Väth [27], the map f will be called *strictly epi (on U)* if

$$\inf\{\|f(x)\| : x \in \partial U\} > 0$$

and there exists $k > 0$ such that for any map $g \in C(\overline{U}, F)$ with $\alpha(g) \leq k$ and $g(x) = 0$ for all $x \in \partial U$, the coincidence equation $f(x) = g(x)$ admits a solution in U . The map f will be called *properly epi (on U)* if $\omega(f) > 0$, $f(x) \neq 0$ for all $x \in \partial U$, and for any compact map $g \in C(\overline{U}, F)$ with $g(x) = 0$ for all $x \in \partial U$, the coincidence equation $f(x) = g(x)$ admits a solution in U . That is, f properly epi on U means that $\omega(f) > 0$ and f is zero-epi on U . It is known, but not trivial to prove, that if f is properly epi on U then it is also strictly epi on U (see e.g. [27]).

Let us now introduce the notion of v -regular and V -regular maps. A map $f \in C(E, F)$ is said to be *v -regular (V-regular)* if it is strictly epi (properly epi) on some U . Given $f \in C(E, E)$, we call the set

$$\phi(f) = \{\lambda \in \mathbb{K} : \lambda I - f \text{ is not } v\text{-regular}\}$$

the *Väth phantom of f* and the set

$$\Phi(f) = \{\lambda \in \mathbb{K} : \lambda I - f \text{ is not } V\text{-regular}\}$$

the *large Väth phantom of f* . We have the following inclusions:

$$\phi(f) \subseteq \Phi(f) \subseteq \sigma_{FMV}(f).$$

That is, the Väth phantoms are both contained in the FuMaVi spectrum.

Let us now discuss some properties of the two phantoms. The following result shows that the phantoms extend the linear spectrum.

Theorem 5.1. *Let $L : E \rightarrow E$ be a bounded linear operator. Then, both the phantom $\phi(L)$ and the large phantom $\Phi(L)$ coincide with the classical spectrum of L .*

Theorem 5.2. *Both the phantom $\phi(f)$ and the large phantom $\Phi(f)$ are closed.*

The next result provides a sufficient condition for the two phantoms to be bounded.

Theorem 5.3. *Assume that $\alpha(f|_{\overline{U}}) < \infty$ for some U . Then, both the phantom $\phi(f)$ and the large phantom $\Phi(f)$ are bounded. More precisely the following inclusion holds:*

$$\Phi(f) \subseteq \left\{ \lambda \in \mathbb{K} : |\lambda| \leq \inf_U \max \left\{ \alpha(f|_{\overline{U}}), \frac{\sup_{x \in \partial U} \|f(x)\|}{\inf_{x \in \partial U} \|x\|} \right\} \right\}.$$

A detailed comparison of spectra and phantoms may be found in the monograph [3]. Furthermore, the short survey [27] provides an interesting comparison between the phantom and the asymptotic spectrum.

6. THE SPECTRUM AT A POINT

In this section we recall a notion of spectrum for nonlinear operators recently introduced by the authors. This spectrum at a point is based on the concept of zero-epi map at a point as well as on some numerical characteristics.

In the sequel we will use the following notation. Let U be an open subset of E , $f \in C(U, F)$ and $p \in U$. Denote by U_p the open neighborhood $\{x \in E : p + x \in U\}$ of $0 \in E$, and define $f_p \in C(U_p, F)$ by $f_p(x) = f(p + x) - f(p)$.

Some numerical characteristics. Let U be an open subset of E , $f \in C(U, F)$ and $p \in U$. We recall the definitions of $\alpha_p(f)$ and $\omega_p(f)$ given in [7]. Roughly speaking, these numbers are the pointwise analogues of $\alpha(f)$ and $\omega(f)$.

Let $B(p, r)$ denote the open ball in E centered at p with radius $r > 0$. Suppose that $B(p, r) \subseteq U$ and consider the number

$$\alpha(f|_{B(p,r)}) = \sup \left\{ \frac{\alpha(f(A))}{\alpha(A)} : A \subseteq B(p, r), \alpha(A) > 0 \right\},$$

which is nondecreasing as a function of r . Hence, we can define

$$\alpha_p(f) = \lim_{r \rightarrow 0} \alpha(f|_{B(p,r)}).$$

Clearly, $\alpha_p(f) \leq \alpha(f)$. Analogously, define

$$\omega_p(f) = \lim_{r \rightarrow 0} \omega(f|_{B(p,r)}).$$

Obviously, $\omega_p(f) \geq \omega(f)$. Notice that $\alpha_p(f) = \alpha_0(f_p)$ and $\omega_p(f) = \omega_0(f_p)$. Let us point out that, if E is finite dimensional, then $\alpha_p(f) = -\infty$ and $\omega_p(f) = +\infty$ for any $p \in U$. Observe also that if f is locally compact, then $\alpha_p(f) = 0$. Moreover, if $\omega_p(f) > 0$, then f is locally proper at p .

For a comprehensive list of properties of $\alpha_p(f)$ and $\omega_p(f)$ we refer to [7].

Remark 6.1. If $f : E \rightarrow F$ is positively homogeneous, then $\alpha_0(f) = \alpha(f)$ and $\omega_0(f) = \omega(f)$.

Clearly, for a bounded linear operator $L : E \rightarrow F$, the numbers $\alpha_p(L)$ and $\omega_p(L)$ do not depend on the point p and coincide, respectively, with $\alpha(L)$ and $\omega(L)$. Furthermore, for the C^1 case the following result holds.

Proposition 6.2 ([7]). *Let $f : U \rightarrow F$ be of class C^1 . Then, for any $p \in U$ we have $\alpha_p(f) = \alpha(f'(p))$ and $\omega_p(f) = \omega(f'(p))$.*

As before, let $f \in C(U, F)$, and fix $p \in U$. Following [16], define

$$|f|_p = \limsup_{x \rightarrow 0} \frac{\|f(p+x) - f(p)\|}{\|x\|}$$

and

$$d_p(f) = \liminf_{x \rightarrow 0} \frac{\|f(p+x) - f(p)\|}{\|x\|}.$$

Notice that $|f|_p = |f_p|_0$ and $d_p(f) = d_0(f_p)$. Following [16], the map f will be called *quasibounded at p* if $|f|_p < +\infty$.

Remark 6.3. If $f : E \rightarrow F$ is positively homogeneous, then $|f|_0$ coincides with the quasinorm of f , and $d_0(f)$ coincides with the number $d(f)$. More precisely, one has

$$|f|_0 = |f| = \sup_{\|x\|=1} \|f(x)\| \quad \text{and} \quad d_0(f) = d(f) = \inf_{\|x\|=1} \|f(x)\|.$$

Evidently, for a bounded linear operator $L : E \rightarrow F$, the number $|L|_p$ does not depend on the point p and coincides with the norm $\|L\|$. Analogously, $d_p(L)$ is independent of p and coincides with $d(L)$.

For the C^1 case the following result holds.

Proposition 6.4 ([16]). *Let $f : U \rightarrow F$ be of class C^1 . Then, for any $p \in U$ we have $|f|_p = \|f'(p)\|$ and $d_p(f) = d(f'(p))$.*

Zero-epi maps at a point. We recall now the following definitions (see [9]). Let U be open in E , $f \in C(U, F)$ and $p \in U$.

Definition 6.5. Given y in F , we say that f is *y -admissible at p* if $f(p) = y$ and $f(x) \neq y$ for any x in a pinched neighborhood of p .

Notice that the map f is y -admissible at p if and only if $f(p) = y$ and f_p is 0-admissible at 0. Furthermore, observe that if f verifies $d_p(f) > 0$ then it is $f(p)$ -admissible at p .

Definition 6.6. We say that f is *y -epi at p* if it is y -admissible at p and y -epi on any sufficiently small neighborhood of p .

Remark 6.7. In view of the localization property of zero-epi maps (see Proposition 4.4), in the previous definition it is not restrictive to require that there exists a bounded open neighborhood U of p such that $f(x) \neq y$ for all $x \in \overline{U}$, $x \neq p$, and f is y -epi on U .

Notice that f is y -epi at p if and only if $f(p) = y$ and f_p is 0-epi at 0.

The following local surjectivity property can be deduced from the corresponding property of zero-epi maps stated in Theorem 4.5 above.

Corollary 6.8. *Let $f \in C(U, F)$ be y -epi at p and locally proper at p . Then, y is an interior point of the image $f(U)$.*

We observe that a bounded linear operator $L : E \rightarrow F$ is y -admissible at p if and only if $Lp = y$ and L is injective. Moreover, if $Lp = y$, then L is y -epi at p if and only if it is 0-epi at 0.

Let $L : E \rightarrow F$ be a linear isomorphism. As a consequence of the Schauder Fixed Point Theorem, it is not difficult to prove that L is zero-epi on any bounded neighborhood of the origin (see [14]). In particular, this implies that L is 0-epi at 0.

The spectrum at a point. We are now ready to define the spectrum of a map at a point (see [9]). We need first to introduce the notion of regular map at a point.

Let U be an open subset of E , $f \in C(U, F)$, and $p \in U$.

Definition 6.9. The map f is said to be *regular at p* if the following conditions hold:

- i) $d_p(f) > 0$;
- ii) $\omega_p(f) > 0$;
- iii) f_p is 0-epi at 0.

Notice that f is regular at p if and only if f_p is regular at 0. Moreover, if f is regular at p and $c \neq 0$, then cf is regular at p as well.

The following stability property for regular maps at a point, which can be regarded as a Rouché-type theorem, is the analogue of Theorem 3.1 above.

Theorem 6.10 (Stability theorem for regular maps, [9]). *Assume that f is regular at p and let $g = f + k$, where $k \in C(U, F)$ is such that $\alpha_p(k) < \omega_p(f)$ and $|k|_p < d_p(f)$. Then g is regular at p .*

Notice that a bounded linear operator $L : E \rightarrow F$ is regular at p if and only if it is regular at 0. The following proposition characterizes the bounded linear operators which are regular at 0.

Proposition 6.11. *Let $L : E \rightarrow F$ be a bounded linear operator. Then L is regular at 0 if and only if it is an isomorphism.*

Let now $f \in C(U, E)$ and $p \in U$. We define the *spectrum of the map f at the point p* as the set

$$\sigma(f, p) = \{\lambda \in \mathbb{K} : \lambda I - f \text{ is not regular at } p\}.$$

It is convenient to define the following subsets of $\sigma(f, p)$:

$$\sigma_\omega(f, p) = \{\lambda \in \mathbb{K} : \omega_p(\lambda I - f) = 0\}, \quad \Sigma(f, p) = \{\lambda \in \mathbb{K} : d_p(\lambda I - f) = 0\},$$

and $\sigma_\pi(f, p) = \sigma_\omega(f, p) \cup \Sigma(f, p)$. We shall call $\sigma_\pi(f, p)$ the *approximate point spectrum of f at p* . We point out that the spectrum $\Sigma(f, p)$ has been introduced in [16] by the last two authors.

Clearly, for a bounded linear operator $L : E \rightarrow E$, $\sigma(L, p)$ and $\sigma_\pi(L, p)$ do not depend on p . Hence, we can simply write $\sigma(L)$ and $\sigma_\pi(L)$ instead of $\sigma(L, p)$ and $\sigma_\pi(L, p)$.

The above notation and definitions are justified by the following result, which is analogous to Theorem 3.2.

Theorem 6.12. *Let $L : E \rightarrow E$ be a bounded linear operator. Then*

1. $\sigma(L)$ coincides with the classical spectrum of L ;
2. $\sigma_\pi(L)$ coincides with the classical approximate point spectrum of L .

The next result shows that, for a positively homogeneous map $f : E \rightarrow E$, the spectrum of f at 0 coincides with the asymptotic spectrum of f . In particular, the same is true for bounded linear operators. The proof is straightforward and, therefore, will be omitted.

Theorem 6.13. *Let $f : E \rightarrow E$ be positively homogeneous. Then*

1. $\sigma(f, 0)$ coincides with the asymptotic spectrum, $\sigma_{FMV}(f)$, of f ;
2. $\sigma_\pi(f, 0)$ coincides with the asymptotic approximate point spectrum $\sigma_{\pi, FMV}(f)$.
More precisely, $\sigma_\omega(f, 0) = \sigma_{\omega, FMV}(f)$ and $\Sigma(f, 0) = \Sigma_{FMV}(f)$. In addition, $\lambda \in \Sigma(f, 0)$ if and only if $\inf_{\|x\|=1} \|\lambda x - f(x)\| = 0$.

Observe that the map $f : \mathbb{C}^2 \rightarrow \mathbb{C}^2$ as in Example 2.3 is positively homogeneous. We already pointed out that $\sigma_{FMV}(f) = \emptyset$. Taking into account Theorem 6.13 it follows that $\sigma(f, 0) = \emptyset$. This shows that also the spectrum at a point may be empty.

Remark 6.14. If E is finite dimensional, then $\sigma_\omega(f, p) = \emptyset$ for any p and hence $\sigma_\pi(f, p) = \Sigma(f, p)$.

Remark 6.15. It is interesting to observe that, for a real function f , the spectrum $\sigma(f, p)$ is completely determined by the *Dini's derivatives* of f at p , that is, by the following four extended real numbers:

$$D_- f(p) = \liminf_{h \rightarrow 0^-} \frac{f(p+h) - f(p)}{h}, \quad D^- f(p) = \limsup_{h \rightarrow 0^-} \frac{f(p+h) - f(p)}{h},$$

$$D_+ f(p) = \liminf_{h \rightarrow 0^+} \frac{f(p+h) - f(p)}{h}, \quad D^+ f(p) = \limsup_{h \rightarrow 0^+} \frac{f(p+h) - f(p)}{h}.$$

It is not difficult to show that $\sigma(f, p)$ is the closed subinterval of \mathbb{R} whose endpoints are, respectively, the smallest and the largest of the Dini's derivatives. Thus, any closed interval (the empty set, a singleton and \mathbb{R} included) is the spectrum at a point

of some continuous function. For example, if all the four Dini's derivatives of f at p are $+\infty$ (or $-\infty$), then $\sigma(f, p) = \emptyset$.

We point out that, even in the one dimensional real case, $\Sigma(f, p)$ need not coincide with $\sigma(f, p)$. In fact, one can check that $\Sigma(f, p)$ is the union of two closed intervals: one with endpoints $D_-f(p)$ and $D^-f(p)$, and the other one with endpoints $D_+f(p)$ and $D^+f(p)$. Hence, $\sigma(f, p)$ is the smallest interval containing $\Sigma(f, p)$, and this agrees with Theorem 6.18 below.

As a consequence of these facts, if f is differentiable at p one gets $\sigma(f, p) = \Sigma(f, p) = \{f'(p)\}$. This agrees with Corollary 6.22 below.

Let us point out that, in view of Remark 6.15, the computation of the spectrum at a point in Examples 2.1, 2.2 and 2.5 is trivial. In the present as well as in the next section we will provide more interesting examples dealing with non-differentiable maps.

The next result, which is a consequence of Theorem 6.10, provides a sufficient condition for the spectrum of f at p to be bounded. Set

$$q_p(f) = \max\{\alpha_p(f), |f|_p\}$$

and define the *spectral radius of f at p* as

$$r_p(f) = \sup\{|\lambda| : \lambda \in \sigma(f, p)\}.$$

Theorem 6.16 ([9]). *We have $r_p(f) \leq q_p(f)$. In particular, if f is locally compact and quasibounded at p , then $\sigma(f, p)$ is bounded.*

In the case of a bounded linear operator $L : E \rightarrow E$, the number $r_p(L)$ is independent of p . Therefore, this number will be denoted by $r(L)$. From Proposition 6.16 above we recover the well known property $r(L) \leq \|L\|$.

The estimates provided in the following proposition will be used in the sequel.

Proposition 6.17. *The following estimates hold:*

1. $\lambda \in \Sigma(f, p)$ implies $d_p(f) \leq |\lambda| \leq |f|_p$;
2. $\lambda \in \sigma_\omega(f, p)$ implies $\omega_p(f) \leq |\lambda| \leq \alpha_p(f)$.

The following result, which is analogous to Theorem 3.3 above, shows that the spectrum at a point shares some important properties with the asymptotic spectrum.

Theorem 6.18 ([9]). *The following properties hold.*

1. $\sigma(f, p)$ is closed;
2. $\sigma_\pi(f, p)$ is closed;
3. $\sigma(f, p) \setminus \sigma_\pi(f, p)$ is open;

$$4. \partial\sigma(f, p) \subseteq \sigma_\pi(f, p).$$

Corollary 6.19. *Let W be a connected component of $\mathbb{K} \setminus \sigma_\pi(f, p)$. Then, W is open in \mathbb{K} and maps of the form $\lambda I - f_p$, with $\lambda \in W$, are either all 0-epi at 0 or all not 0-epi at 0.*

Corollary 6.20. *The following assertions hold.*

- i) *Assume that $\mathbb{K} = \mathbb{C}$, $\sigma(f, p)$ is bounded, and λ belongs to the unbounded component of $\mathbb{C} \setminus \sigma_\pi(f, p)$. Then $\lambda I - f$ is regular at p . In particular (as pointed out by J.R.L. Webb in a private communication), if $\sigma_\pi(f, p)$ is countable, then $\sigma(f, p) = \sigma_\pi(f, p)$.*
- ii) *Assume that $\mathbb{K} = \mathbb{R}$, $\sigma(f, p)$ is bounded from above (resp. below), and λ belongs to the right (resp. left) unbounded component of $\mathbb{R} \setminus \sigma_\pi(f, p)$. Then $\lambda I - f$ is regular at p .*

In what follows the notation $\sigma(f, p) \equiv \sigma(g, p)$ stands for $\sigma(f, p) = \sigma(g, p)$, $\sigma_\omega(f, p) = \sigma_\omega(g, p)$, and $\Sigma(f, p) = \Sigma(g, p)$. Recall that $q_p(f) = \max\{\alpha_p(f), |f|_p\}$.

Theorem 6.21 ([9]). *Given an open subset U of E , $f, g \in C(U, E)$ and $p \in U$, one has*

- 1. $\sigma(cf, p) \equiv c\sigma(f, p)$, for any $c \in \mathbb{K}$;
- 2. $\sigma(c + f, p) \equiv c + \sigma(f, p)$, for any $c \in \mathbb{K}$;
- 3. $q_p(f - g) = 0$ implies $\sigma(f, p) \equiv \sigma(g, p)$.

For C^1 maps we have the following result which is a direct consequence of property (3) in Theorem 6.21.

Corollary 6.22. *Let $f : U \rightarrow E$ be of class C^1 and $p \in U$. Then, $\sigma(f, p) \equiv \sigma(f'(p))$.*

Observe that the equivalence $\sigma(f, p) \equiv \sigma(f'(p))$ holds true even when the map $f \in C(U, E)$ is merely Fréchet differentiable at the point $p \in U$, provided that the remainder $\phi \in C(U, E)$, defined as

$$\phi(x) = f(x) - f'(p)(x - p), \quad x \in U,$$

verifies $\alpha_p(\phi) = 0$. This is the case, for instance, if $f = g + h$, where g is of class C^1 and h is locally compact and Fréchet differentiable at p (but not necessarily C^1). As an example, consider the map $f : E \rightarrow E$ defined by

$$f(x) = \begin{cases} x + \|x\|^2 \left(\sin \frac{1}{\|x\|} \right) v & \text{if } x \neq 0, \\ 0 & \text{if } x = 0, \end{cases}$$

where $v \in E \setminus \{0\}$ is given, and $p = 0$.

In the case when the map f is of class C^1 , Corollary 6.22 above implies that the multivalued map that associates to every point p the spectrum $\sigma(f, p) \subseteq \mathbb{K}$ is upper semicontinuous. This depends on the well known fact that so is the map which associates to any bounded linear operator $L : E \rightarrow E$ its spectrum $\sigma(L)$. The next one-dimensional example shows that the multivalued map $p \mapsto \sigma(f, p) \subseteq \mathbb{K}$ need not be upper semicontinuous if f is merely C^0 .

Example 6.23. Let $f : \mathbb{R} \rightarrow \mathbb{R}$ be defined by $f(x) = x^2 \sin(1/x)$, if $x \neq 0$ and $f(0) = 0$. Notice that f is C^1 on $\mathbb{R} \setminus \{0\}$ and merely differentiable at 0 with $f'(0) = 0$. Thus, as pointed out above, $\sigma(f, 0) = \{0\}$. Consequently, the multivalued map $p \mapsto \sigma(f, p) = \{f'(p)\}$ is not upper semicontinuous at 0 since f' is not continuous at 0.

The next example in the infinite dimensional context regards an interesting differentiable map.

Example 6.24. Let E be a real Hilbert space (of dimension greater than 1), and consider the nonlinear map $f(x) = \|x\|x$. Observe that f is Fréchet differentiable at any $p \in E$ with

$$f'(p)v = \|p\|v + \frac{\langle p, v \rangle}{\|p\|} p, \quad v \in E$$

if $p \neq 0$, and $f'(0) = 0$. Hence, by Corollary 6.22 we have $\sigma(f, p) = \sigma(f'(p))$. Given $p \neq 0$, in order to compute $\sigma(f'(p))$, observe that $f'(p)$ is of the form $L = cI + K$, with $c \in \mathbb{R}$ and $K : E \rightarrow E$ with finite dimensional image, say E_0 (in this case $\dim E_0 = 1$). Since $\sigma(L) = \{c\} \cup \sigma(L_0)$, where L_0 denotes the restriction of L to E_0 , we get $\sigma(f, p) = \sigma(f'(p)) = \{\|p\|\} \cup \{2\|p\|\}$ if $p \neq 0$ and, clearly, $\sigma(f, 0) = \sigma(f'(0)) = \{0\}$.

We already pointed out that the spectrum at a point may be empty. On the other hand, it satisfies the following nonemptiness property (which is a straightforward consequence of Corollary 6.22 above), as the Neuberger spectrum does.

Corollary 6.25. *If $\mathbb{K} = \mathbb{C}$ and $f : U \rightarrow E$ is of class C^1 , then for any $p \in U$ the spectrum $\sigma(f, p)$ is nonempty.*

Also the following property is in common with all the other spectra considered up to now.

Proposition 6.26. *Assume $\dim E = +\infty$ and let f be locally compact. Then, $0 \in \sigma(f, p)$. More precisely, $\sigma_\omega(f, p) = \{0\}$. Thus, $\sigma_\pi(f, p) = \{0\} \cup \Sigma(f, p)$.*

The following simple examples illustrate three “pathological cases” for the spectrum at a point.

Example 6.27. Let $f : \mathbb{R} \rightarrow \mathbb{R}$, $f(x) = \text{sign}(x)\sqrt{|x|}$. Then, $\Sigma(f, 0) = \sigma(f, 0) = \emptyset$.

Example 6.28. Let $f : \mathbb{R} \rightarrow \mathbb{R}$, $f(x) = \sqrt{|x|}$. Then, $\Sigma(f, 0) = \emptyset$ and $\sigma(f, 0) = \mathbb{R}$.

Example 6.29. Let $f : \mathbb{R} \rightarrow \mathbb{R}$ be such that $f(x) = \sqrt{|x|} \sin(1/x)$ if $x \neq 0$ and $f(0) = 0$. Clearly, $\sigma_\pi(f, 0) = \Sigma(f, 0) = \mathbb{R}$.

In the case of positively homogeneous maps, it is notably meaningful to introduce the concept of eigenvalue. Let $f : E \rightarrow E$ be positively homogeneous. As in the linear case, we say that $\lambda \in \mathbb{K}$ is an *eigenvalue of f* if the equation $\lambda x = f(x)$ admits a nontrivial solution.

Proposition 6.30. *Assume $f : E \rightarrow E$ positively homogeneous and $\lambda \notin \sigma_\omega(f, 0)$. Then, $\lambda \in \Sigma(f, 0)$ if and only if λ is an eigenvalue of f .*

Corollary 6.31. *The following assertions hold.*

- i) *Assume $\dim E = +\infty$ and let $f : E \rightarrow E$ be positively homogeneous and locally compact. Then, $\Sigma(f, 0) \setminus \{0\} = \{\lambda \in \mathbb{K} \setminus \{0\} : \lambda \text{ eigenvalue of } f\}$.*
- ii) *Assume E finite dimensional and $f : E \rightarrow E$ positively homogeneous. Then, $\Sigma(f, 0) = \{\lambda \in \mathbb{K} : \lambda \text{ eigenvalue of } f\}$.*

In Table 1 we summarize the main properties of the various spectra we have considered so far.

<i>Spectrum</i>	Nonempty	Closed	Bounded	Compact
$\sigma_R(f)$	No	No	No	No
$\sigma_N(f)$	Yes	No	No	No
$\sigma_K(f)$	No ^a	Yes	Yes	Yes
$\sigma_{FMV}(f)$	No ^a	Yes	No ^b	No ^b
$\sigma_F(f)$	No ^a	Yes	No ^c	No ^c
$\sigma(f, p)$	No ^d	Yes	No ^e	No ^e

^a Yes if $\dim E = \infty$ and f is completely continuous.

^b Yes if $\alpha(f) < \infty$ and f is quasibounded.

^c Yes if $\alpha(f) < \infty$ and $M(f) < \infty$.

^d Yes if $\dim E = \infty$ and f is locally compact.

^e Yes if $\alpha_p(f) < \infty$ and f is quasibounded at p .

TABLE 1

7. BIFURCATION AND ILLUSTRATING EXAMPLES

In this section we describe some applications of the spectrum at a point to bifurcation problems in the non-differentiable case. We close this paper with some examples illustrating some peculiarities of the spectrum at a point.

Let U be an open subset of E and $f \in C(U, E)$. Assume that $0 \in U$ and $f(0) = 0$, and consider the equation

$$\lambda x = f(x), \quad \lambda \in \mathbb{K}. \quad (7.1)$$

A solution (λ, x) of (7.1) is called *nontrivial* if $x \neq 0$. We recall that $\lambda \in \mathbb{K}$ is a *bifurcation point* for f if any neighborhood of $(\lambda, 0)$ in $\mathbb{K} \times E$ contains a nontrivial solution of (7.1). We will denote by $\mathcal{B}(f)$ the set of bifurcation points of f . Notice that $\mathcal{B}(f)$ is closed since $\lambda \in \mathcal{B}(f)$ if and only if $(\lambda, 0)$ belongs to the closure \overline{S} of the set S of the nontrivial solutions of (7.1).

It is well known that if f is Fréchet differentiable at 0 then the set $\mathcal{B}(f)$ of bifurcation points of f is contained in the spectrum $\sigma(f'(0))$ of the Fréchet derivative $f'(0)$. The next proposition (see also [16]) extends this necessary condition.

Proposition 7.1 ([9]). *The set $\mathcal{B}(f)$ is contained in $\Sigma(f, 0)$, and hence in $\sigma_\pi(f, 0)$.*

Remark 7.2. As in the linear case, for a positively homogeneous map $f : E \rightarrow E$ we have that if $\lambda \in \mathbb{K}$ is an eigenvalue of f then $\lambda \in \mathcal{B}(f)$. If, moreover, $\omega(\lambda I - f) > 0$, the converse is also true in view of Proposition 6.30 and Proposition 7.1 above.

The following result provides a sufficient condition for the existence of bifurcation points. It is in the spirit of Theorem 5.1 in [16], where f is assumed to be locally compact and quasibounded at 0. Notice that the Leray–Schauder degree cannot be used here, since we do not assume f to be locally compact.

Theorem 7.3 ([9]). *Let $\lambda_0, \lambda_1 \in \mathbb{K}$. Assume $\lambda_0 \in \sigma(f, 0) \setminus \sigma_\pi(f, 0)$ and $\lambda_1 \notin \sigma(f, 0)$. Then, $\sigma_\omega(f, 0) \cup \mathcal{B}(f)$ separates λ_0 from λ_1 ; that is, λ_0 and λ_1 belong to different components of $\mathbb{K} \setminus (\sigma_\omega(f, 0) \cup \mathcal{B}(f))$.*

Corollary 7.4. *Let $\lambda_0 \in \sigma(f, 0) \setminus \sigma_\pi(f, 0)$, and assume that $\sigma(f, 0)$ is bounded. Then, the connected component of $\mathbb{K} \setminus (\sigma_\omega(f, 0) \cup \mathcal{B}(f))$ containing λ_0 is bounded.*

Proposition 7.5 below extends Theorem 2.1 in [16] by replacing the assumption “ f quasibounded at p ” with the weaker condition “ $\sigma(f, p)$ bounded”. We wish to stress the fact that, contrary to the proof of [16, Theorem 2.1], here no degree theory is involved. We wish further to observe that a result of this type could not be stated in [16] because of the lack of an exhaustive notion of spectrum at a point. The same proposition exhibits an exclusively nonlinear phenomenon since, in the compact linear case, zero always belongs to the approximate point spectrum. An example illustrating this peculiarity will be given below.

Proposition 7.5 ([9]). *Let U be an open subset of E containing the origin, and suppose $\dim E = +\infty$. Let $f \in C(U, E)$ be locally compact, and assume that $\sigma(f, 0)$ is bounded. Then, $0 \notin \Sigma(f, 0)$ implies that the connected component of $\mathbb{K} \setminus \mathcal{B}(f)$ containing 0 is bounded.*

Let us examine now some illustrating examples. We consider first the case $E = \mathbb{C}$. Since \mathbb{C} is finite dimensional, given $f : \mathbb{C} \rightarrow \mathbb{C}$ and $p \in \mathbb{C}$, we have $\sigma_\pi(f, p) = \Sigma(f, p)$. If, in addition, f is positively homogeneous, then

$$\Sigma(f, 0) = \{\lambda \in \mathbb{C} : \lambda z = f(z) \text{ for some } z \neq 0\} = \mathcal{B}(f)$$

(see Remark 7.2).

Example 7.6. Let $f : \mathbb{C} \rightarrow \mathbb{C}$ be defined as $f(x + iy) = |x| + iy$. The map f is positively homogeneous and, consequently, $\lambda = a + ib$ belongs to $\Sigma(f, 0)$ if and only if the equation $(a + ib)(x + iy) - (|x| + iy) = 0$ admits a solution $x + iy$ in S^1 . An easy computation shows that $\Sigma(f, 0) = S^1$. Observe that $d_0(f) = |f|_0 = 1$, and this implies that the spectrum $\sigma(f, 0)$ is bounded. Moreover, f is not zero-epi at 0. To see this notice that, given $w \in \mathbb{C}$ with negative real part, the equation $f(z) = w$ has no solutions. Finally, since $\partial\sigma(f, 0) \subseteq \Sigma(f, 0)$, we conclude that $\sigma(f, 0) = \{a + ib : a^2 + b^2 \leq 1\}$ and $\Sigma(f, 0) = S^1$.

Example 7.7. Let $f : \mathbb{C} \rightarrow \mathbb{C}$ be defined as $f(x + iy) = sx + ty + i(ux + vy)$, where s, t, u, v are given real constants. The map f is positively homogeneous, and linear if regarded from \mathbb{R}^2 into itself. Consequently, $\lambda = a + ib$ belongs to $\Sigma(f, 0)$ if and only if the equation $(a + ib)(x + iy) - (sx + ty + i(ux + vy)) = 0$ admits a solution $x + iy$ with $x^2 + y^2 > 0$; that is, if and only if the homogeneous linear system

$$\begin{cases} (a - s)x - (b + t)y = 0 \\ (b - u)x + (a - v)y = 0 \end{cases}$$

admits a nontrivial solution (x, y) . This fact is equivalent to the condition

$$\det \begin{pmatrix} a - s & -(b + t) \\ b - u & a - v \end{pmatrix} = 0,$$

from which we get $a^2 + b^2 - (s + v)a - (u - t)b + sv - tu = 0$. This is the equation of the circle S_0 , centered at $(\frac{s+v}{2}, \frac{u-t}{2})$ with radius

$$r = \sqrt{\frac{(s + v)^2}{4} + \frac{(u - t)^2}{4} - sv + tu}.$$

Observe that $\sigma(f, 0) = \Sigma(f, 0)$. Indeed, assume that $\lambda = a + ib$ does not belong to $\Sigma(f, 0)$, that is

$$\det \begin{pmatrix} a - s & -(b + t) \\ b - u & a - v \end{pmatrix} \neq 0.$$

This implies that $\lambda I - f$ is a linear isomorphism as a map from \mathbb{R}^2 into itself. In particular, $\lambda I - f$ is a homeomorphism as a map from \mathbb{C} into \mathbb{C} . It follows $\lambda \notin \sigma(f, 0)$ in view of Proposition 4.3. Hence, the whole spectrum $\sigma(f, 0)$ coincides with the circle S_0 .

Notice that the spectrum reduces to a point (i.e. $r = 0$) if and only if $s = v$ and $t = -u$; that is, if and only if f is linear as a complex map.

Example 7.8. Let $g : \mathbb{C} \rightarrow \mathbb{C}$ be defined by $g(x + iy) = \sqrt{x^2 + y^2} + iy^n$, with $n \geq 2$. As a consequence of Theorem 6.21-(3), we have $\sigma(g, 0) \equiv \sigma(f, 0)$, where $f : \mathbb{C} \rightarrow \mathbb{C}$ is the positively homogeneous map defined as $f(x + iy) = \sqrt{x^2 + y^2}$. Now, it is not difficult to prove that $\Sigma(f, 0) = S^1$. Moreover, $\sigma(f, 0) = \{a + ib : a^2 + b^2 \leq 1\}$ since 0 is not in the interior of the image of f (so f is not zero-epi at 0). Consequently, $\Sigma(g, 0) = S^1$ and $\sigma(g, 0) = \{a + ib : a^2 + b^2 \leq 1\}$. Hence, by Theorem 7.3, we get $\mathcal{B}(g) = \Sigma(g, 0) = S^1$.

Example 7.9. Let $f : \mathbb{C} \rightarrow \mathbb{C}$ be defined as $f(x + iy) = \sqrt{x^2 + y^2} + iy$. Since f is positively homogeneous, one can show that $a + ib \in \Sigma(f, 0)$ if and only if

$$(a - 1)^2 + b^2 = (a^2 + b^2 - a)^2,$$

which is the equation of a closed curve Γ (a cardioid). The curve Γ divides the complex plane in two connected components, Ω_0 (containing 0) and Ω_1 (unbounded). Clearly, $\lambda \notin \sigma(f, 0)$ if λ belongs to Ω_1 . Furthermore, $\lambda \in \sigma(f, 0)$ for any $\lambda \in \Omega_0$ since f is not zero-epi at 0. Hence, $\sigma(f, 0) = \overline{\Omega_0} = \Omega_0 \cup \Gamma$ and $\Sigma(f, 0) = \Gamma$ (see Figure 1).

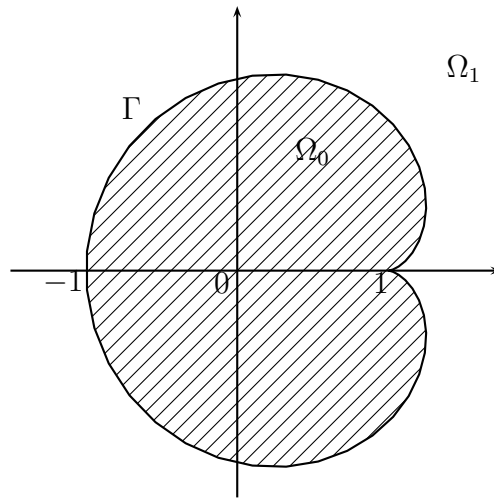

FIGURE 1. The spectrum of $f : \mathbb{C} \rightarrow \mathbb{C}$, $x + iy \mapsto \sqrt{x^2 + y^2} + iy$.

Example 7.10. Let $f : \mathbb{C} \rightarrow \mathbb{C}$ be defined as $f(x + iy) = |x|/2 + iy$. Notice that $d_0(f) = 1/2$ and $|f|_0 = 1$. Since f is positively homogeneous, one can show (see e.g. [15]) that $\Sigma(f, 0)$ is the union of two circles: $S_+ = \{\lambda \in \mathbb{C} : |\lambda - \frac{1}{4}| = \frac{3}{4}\}$ and $S_- = \{\lambda \in \mathbb{C} : |\lambda - \frac{3}{4}| = \frac{1}{4}\}$. Consequently, $\mathbb{C} \setminus (S_+ \cup S_-)$ consists of three connected components, Ω_0 (containing 0), Ω_1 (surrounded by S_-) and Ω_2 (unbounded). One can check that, when λ belongs to $\Omega_1 \cup \Omega_2$, the map $\lambda I - f$ is a local homeomorphism around zero. Thus, $\lambda \notin \sigma(f, 0)$ on the basis of Proposition 4.3. Moreover, since

f is not zero-epi at 0, we get $\lambda \in \sigma(f, 0)$ for all $\lambda \in \Omega_0$. Hence, $\sigma(f, 0) = \overline{\Omega_0} = \Omega_0 \cup (S_+ \cup S_-)$ and $\Sigma(f, 0) = S_+ \cup S_-$ (see Figure 2).

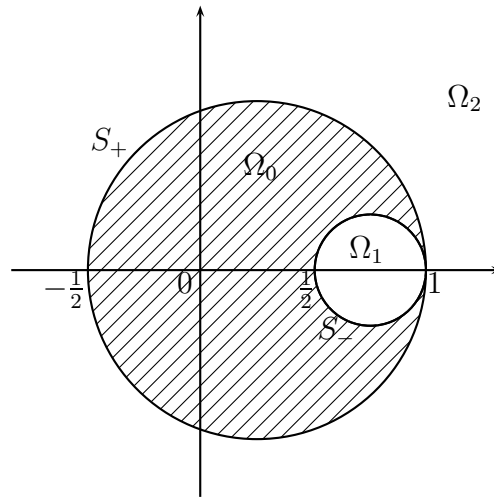

FIGURE 2. The spectrum of $f : \mathbb{C} \rightarrow \mathbb{C}, x + iy \mapsto \frac{|x|}{2} + iy$.

We close with an example in the infinite dimensional context.

Example 7.11. Let $f : \ell^2(\mathbb{C}) \rightarrow \ell^2(\mathbb{C})$ be defined by

$$f(z) = (\|z\|, z_1, z_2, z_3, \dots),$$

where $z = (z_1, z_2, z_3, \dots)$. Notice that f is positively homogeneous, and is the sum of the *right-shift operator* $L : \ell^2(\mathbb{C}) \rightarrow \ell^2(\mathbb{C})$, defined as $Lz = (0, z_1, z_2, z_3, \dots)$, and the finite dimensional map $k : \ell^2(\mathbb{C}) \rightarrow \ell^2(\mathbb{C})$, defined as $k(z) = (\|z\|, 0, 0, 0, \dots)$.

An easy computation shows that $d(f) = |f| = \sqrt{2}$. Moreover, $\alpha(f) = \omega(f) = 1$. Indeed, since k is compact and $f = L + k$, we have $\alpha(f) = \alpha(L)$ and $\omega(f) = \omega(L)$. Now, $\alpha(L) = \omega(L) = 1$, L being an isometry between the space $\ell^2(\mathbb{C})$ and a subspace of codimension one. Therefore, Proposition 6.17 implies $\sigma_\omega(f, 0) \subseteq \{\lambda \in \mathbb{C} : |\lambda| = 1\}$ and $\Sigma(f, 0) \subseteq \{\lambda \in \mathbb{C} : |\lambda| = \sqrt{2}\}$. Let us show that the converse inclusions hold.

First, let us prove that $\sigma_\omega(f, 0) = S^1$. Since $\omega(\lambda I - f) = \omega(\lambda I - L)$, it is enough to show that $\omega(\lambda I - L) = 0$ when $|\lambda| = 1$. To this end, recall that a linear operator T is left semi-Fredholm if and only if $\omega(T) > 0$. Thus, $\lambda I - L$ is left semi-Fredholm for $|\lambda| \neq 1$. Recall also that the index of $\lambda I - L$,

$$\text{ind}(\lambda I - L) = \dim \text{Ker}(\lambda I - L) - \dim \text{coKer}(\lambda I - L) \in \{-\infty\} \cup \mathbb{Z},$$

depends continuously on λ . Therefore, it is constant on any connected set contained in $\mathbb{C} \setminus S^1$. This implies that $\text{ind}(\lambda I - L) = -1$ when $|\lambda| < 1$ since $\text{ind}(-L) = -1$. On the other hand, $\text{ind}(\lambda I - L) = 0$ if $|\lambda| > 1$ since, as well known, $\sigma(L) = \{\lambda \in \mathbb{C} : |\lambda| \leq 1\}$.

Thus, the subset $\sigma_\omega(L)$ of S^1 separates the two open sets $\{\lambda \in \mathbb{C} : |\lambda| < 1\}$ and $\{\lambda \in \mathbb{C} : |\lambda| > 1\}$. Consequently, $\sigma_\omega(L) = S^1$. Hence, $\sigma_\omega(f, 0) = S^1$.

To show that $\Sigma(f, 0) = \{\lambda \in \mathbb{C} : |\lambda| = \sqrt{2}\}$, assume $|\lambda| = \sqrt{2}$. Since $\lambda \notin \sigma_\omega(f, 0)$, Proposition 6.30 implies that $\lambda \in \Sigma(f, 0)$ if and only if λ is an eigenvalue of f . Simple computations show that this condition is satisfied when $|\lambda| = \sqrt{2}$.

As a consequence of the above arguments, $\sigma_\pi(f, 0)$ is the union of two circles centered at the origin. Now, observe that $q_0(f) = \max\{\alpha_0(f), |f|_0\} = \sqrt{2}$ and hence $\sigma(f, 0) \subseteq \{\lambda \in \mathbb{C} : |\lambda| \leq \sqrt{2}\}$. Let us prove that $\sigma(f, 0) = \{\lambda \in \mathbb{C} : |\lambda| \leq \sqrt{2}\}$. For this purpose remember that, if W is a connected component of $\mathbb{C} \setminus \sigma_\pi(f, 0)$, then the maps of the form $\lambda - f$, with $\lambda \in W$, are either all zero-epi at 0 or all not zero-epi at 0 (see Corollary 6.19).

Notice that, if $|\lambda| < 1$, then $\lambda I - f$ is not zero-epi at 0. Indeed, set $e_1 = (1, 0, 0, \dots)$ and observe that, given $\varepsilon > 0$, the equation $f(z) = -\varepsilon e_1$ has no solutions. Consequently, f is not zero-epi at 0.

Let us show that $\lambda I - f$ is not 0-epi at 0 also for $1 < |\lambda| < \sqrt{2}$. Indeed, fix $\lambda \in \mathbb{C}$ with $1 < |\lambda| < \sqrt{2}$. We claim that, given $\varepsilon > 0$, the equation

$$\lambda z - f(z) = \varepsilon e_1, \quad z \in E \tag{7.2}$$

has no solutions. Recall that $\lambda I - L$ is an isomorphism and set $v_\lambda = (\lambda I - L)^{-1}(e_1)$. Since f is the sum of L and k , and the image of k lies in the subspace spanned by e_1 , the solutions of (7.2) lie in the one dimensional subspace E_λ spanned by v_λ . Therefore, any solution of (7.2) is of the type ξv_λ , $\xi \in \mathbb{C}$. An easy computation shows that $\|v_\lambda\|^2 = \frac{1}{|\lambda|^2 - 1}$. Thus,

$$\lambda(\xi v_\lambda) - f(\xi v_\lambda) = \xi e_1 - \|\xi v_\lambda\| e_1 = \left(\xi - |\xi| \frac{1}{\sqrt{|\lambda|^2 - 1}} \right) e_1.$$

Consider now the equation

$$\xi - |\xi| \frac{1}{\sqrt{|\lambda|^2 - 1}} = \varepsilon, \quad \xi \in \mathbb{C} \tag{7.3}$$

which is equivalent to (7.2). It is not difficult to see that equation (7.3) has no solutions when $1 < |\lambda| < \sqrt{2}$. Consequently, equation (7.2) has no solution, as claimed. Hence, $\lambda I - f$ is not zero-epi at 0 when $1 < |\lambda| < \sqrt{2}$.

From the above discussion we get $\sigma(f, 0) = \{\lambda \in \mathbb{C} : |\lambda| \leq \sqrt{2}\}$.

Consider now any map $h : \ell^2(\mathbb{C}) \rightarrow \ell^2(\mathbb{C})$ which is compact and such that $h(z) = o(\|z\|)$ as $\|z\| \rightarrow 0$, and let $g = f + h$. Then, as a consequence of Theorem 6.21-(3), we have $\sigma(g, 0) \equiv \sigma(f, 0)$. In particular, $\sigma(g, 0) = \{\lambda \in \mathbb{C} : |\lambda| \leq \sqrt{2}\} = \Omega_0$. Moreover, $\sigma_\omega(g, 0) = S^1$ and $\Sigma(g, 0) = \{\lambda \in \mathbb{C} : |\lambda| = \sqrt{2}\} = \Gamma$ (see Figure 3). Hence, from Theorem 7.3, it follows that any $\lambda \in \mathbb{C}$ with $|\lambda| = \sqrt{2}$ is a bifurcation point for

g . That is,

$$\mathcal{B}(g) = \{\lambda \in \mathbb{C} : |\lambda| = \sqrt{2}\} = \Gamma.$$

In view of Theorem 7.3, this stability of the set of bifurcation points depends on the fact that $\Sigma(f, 0)$ locally separates $\sigma(f, 0)$ from its complement.

Notice that in the above example we have detected a bifurcation phenomenon that cannot be investigated via the classical Leray–Schauder degree theory. Moreover, since the map f is a compact perturbation of a linear Fredholm operator of negative index, also the more recent degree theory for compact perturbations of Fredholm operators of index zero (see [6] and references therein) cannot be applied.

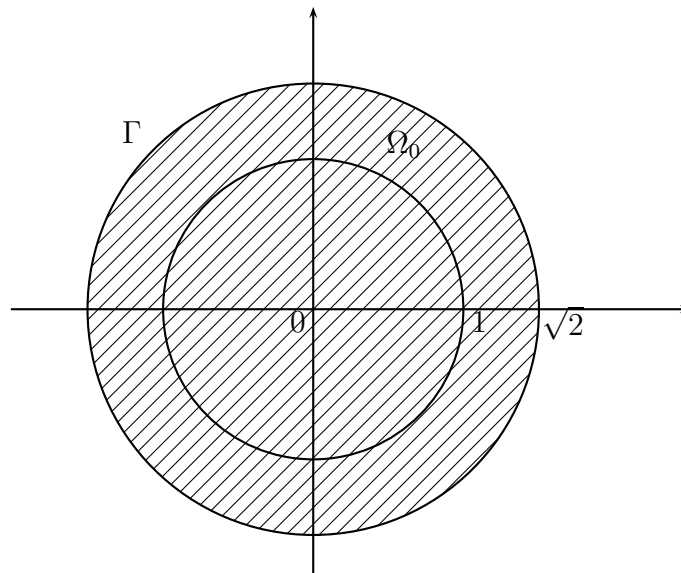

FIGURE 3. The spectrum of $f : \ell^2(\mathbb{C}) \rightarrow \ell^2(\mathbb{C})$, $z \mapsto (\|z\|, z_1, z_2, z_3, \dots)$.

REFERENCES

- [1] J. Appell, *Introducción a la teoría espectral de los operadores no lineales*, unpublished lecture notes.
- [2] J. Appell, E. De Pascale and A. Vignoli, A comparison of different spectra for nonlinear operators, *Nonlinear Anal. TMA* **40** (2000), 73–90.
- [3] J. Appell, E. De Pascale and A. Vignoli, *Nonlinear spectral theory*, de Gruyter, Berlin, 2004.
- [4] J. Appell and M. Dörfner, Some spectral theory for nonlinear operators, *Nonlinear Anal. TMA* **28** (1997), 1955–1976.
- [5] J. Appell, E. Giorgieri and M. Vãth, On a class of maps related to the Furi–Martelli–Vignoli spectrum, *Ann. Mat. Pura Appl.* **179** (2001), 215–228.
- [6] P. Benevieri and M. Furi, Degree for locally compact perturbations of Fredholm maps in Banach spaces, *Abstr. Appl. Anal.* **2006**, Art. ID 64764, 20 pp.
- [7] A. Calamai, The Invariance of Domain Theorem for compact perturbations of nonlinear Fredholm maps of index zero, *Nonlinear Funct. Anal. Appl.* **9** (2004), 185–194.
- [8] A. Calamai, *A degree theory for a class of noncompact perturbations of Fredholm maps*, PhD Thesis, Università di Firenze, 2005.

- [9] A. Calamai, M. Furi and A. Vignoli, A new spectrum for nonlinear operators in Banach spaces, *Nonlinear Funct. Anal. Appl.*, to appear.
- [10] M. Dörfner, *Spektraltheorie für nichtlineare Operatoren*, PhD Thesis, Universität Würzburg, 1997.
- [11] W. Feng, A new spectral theory for nonlinear operators and its applications, *Abstr. Appl. Anal.* **2** (1997) 163–183.
- [12] M. Furi, M. Martelli and A. Vignoli, Stably solvable operators in Banach spaces, *Atti Accad. Naz. Lincei Rend. Cl. Sci. Fis. Mat. Nat.* **60** (1976) 21–26.
- [13] M. Furi, M. Martelli and A. Vignoli, Contributions to the spectral theory for nonlinear operators in Banach spaces, *Ann. Mat. Pura Appl.* **118** (1978), 229–294.
- [14] M. Furi, M. Martelli and A. Vignoli, On the solvability of nonlinear operator equations in normed spaces, *Ann. Mat. Pura Appl.* **124** (1980), 321–343.
- [15] M. Furi and A. Vignoli, A nonlinear spectral approach to surjectivity in Banach spaces, *J. Funct. Anal.* **20** (1975), 304–318.
- [16] M. Furi and A. Vignoli, Spectrum for nonlinear maps and bifurcation in the non differentiable case, *Ann. Mat. Pura Appl.* **4** (1977), 265–285.
- [17] K. Georg and M. Martelli, On spectral theory for nonlinear operators, *J. Funct. Anal.* **24** (1977), 140–147.
- [18] G. Infante and J.R.L. Webb, A finite dimensional approach to nonlinear spectral theory, *Nonlinear Anal.* **51** (2002), 171–188.
- [19] R.I. Kachurovskij, Regular points, spectrum and eigenfunctions of nonlinear operators, *Dokl. Akad. Nauk SSSR* **188** (1969) 274–277 (Russian. English translation: Soviet Math. Dokl. **10** (1969), 1101–1105).
- [20] C. Kuratowski, *Topologie*, Monografie Matematyczne **20**, Warszawa, 1958.
- [21] I.J. Maddox and A.W. Wickstead, The spectrum of uniformly Lipschitz mappings, *Proc. Royal Irish Acad.* **89** (1989), 101–114.
- [22] E.L. May, Localizing the spectrum, *Pacific J. Math.* **44** (1973), 211–218.
- [23] J.W. Neuberger, Existence of a spectrum for nonlinear transformations, *Pacific J. Math.* **31** (1969), 157–159.
- [24] A. Rhodius, Der numerische Wertebereich und die Lösbarkeit linearer und nichtlinearer Operatorengleichungen, *Math. Nachr.* **79** (1977), 343–360.
- [25] P. Santucci and M. Väth, On the definition of eigenvalues for nonlinear operators, *Nonlinear Anal.* **40** (2000), 565–576.
- [26] P. Santucci and M. Väth, Grasping the phantom: a new approach to nonlinear spectral theory, *Ann. Mat. Pura Appl.* **180** (2001), 255–284.
- [27] M. Väth, The Furi–Martelli–Vignoli spectrum vs. the phantom, *Nonlinear Anal.* **47** (2001), 2237–2248.
- [28] M. Väth, Coincidence points of function pairs based on compactness properties, *Glasg. Math. J.* **44** (2002), 209–230.