

Explicit De-Coupled Group AOR Method for solving Elliptic Partial Differential Equations

W. S. Yousif¹ and M. Madalena Martins²

¹Department of Computer Science, Loughborough University, Loughborough, UK.

²Department of Mathematics, University of Coimbra, 3000 Coimbra, Portugal or Instituto de Telecomunicações de Coimbra, University of Coimbra, 3000 Coimbra, Portugal.

Abstract

The explicit group successive overrelaxation (EGSOR) methods which approximates the solution of the sparse linear systems derived from the discretisation of self-adjoint elliptic partial differential equations have been presented (Yousif & Evans, 1986) and it has been shown that these methods are faster and with a smaller computational effort in comparison with the implicit 1-line and 2-line block successive overrelaxation (SOR) iterative methods. Martins, Yousif and Evans (2002) introduced a new explicit 4-point group accelerated overrelaxation (EGAOR) iterative method and made a comparison with the point AOR method for the model problem showing its computational advantages. The aim of this paper is to present an explicit 4-point de-coupled group accelerated overrelaxation iterative (EDGAOR) method and to show that it is faster than the explicit 4-point group accelerated overrelaxation (EGAOR) iterative method.

KEY WORDS: Explicit Decoupled Group, rotated finite difference, 4 point group, Poisson's equation.

C.R. CATEGORIES: G.1.3, G.1.8.

1. INTRODUCTION AND PRELIMINARIES

Many boundary value problems arising in partial differential equations, nonlinear systems, problems of eigenvalues and other subjects lead us to the linear system of equations.

$$A u = b, \tag{1.1}$$

where $A \in C^{n \times n}$ is a given non-singular matrix with non vanishing diagonal entries, $b \in C^n$ is a known vector and u is the unknown vector. To approximate the solution of (1.1) we can use the Accelerated Overrelaxation iterative method (AOR) introduced in (Hadjidimos, 1978), or the 4-point group accelerated overrelaxation (EGAOR)

Iterative method (Martins, Yousif and Evans, 2002) which involves two real parameters r and ω with $\omega \neq 0$. For some special values of the two parameters we can obtain the Jacobi (J), the Gauss-Seidel (GS), Simultaneous Overrelaxation (JOR) and Successive

Overrelaxation (SOR) methods or their 4- point group versions.

Let us consider the linear self-adjoint elliptic equation,

$$\frac{\partial}{\partial x} \left(A(x, y) \frac{\partial U}{\partial x} \right) + \frac{\partial}{\partial y} \left(B(x, y) \frac{\partial U}{\partial y} \right) - F(x, y)U = G(x, y), \quad (x, y) \in \Omega \tag{1.2}$$

$$U(x, y) = g(x, y), \quad (x, y) \in \partial\Omega \tag{1.3}$$

defined in a bounded region Ω , where $A(x, y) > 0, B(x, y) > 0$ and $F(x, y) \geq 0$ and $\partial\Omega$ is the boundary of Ω . For simplicity, we will work with Laplace’s equation

$$\frac{\partial^2 U}{\partial x^2} + \frac{\partial^2 U}{\partial y^2} = 0 \tag{1.4}$$

defined in the unit square, $0 \leq x, y \leq 1$, with m^2 internal mesh points in the region shown in figure 1. This equation is obtained from (1.2) if we consider $A(x, y) = B(x, y) = 1$ and $F(x, y) = G(x, y) = 0$.

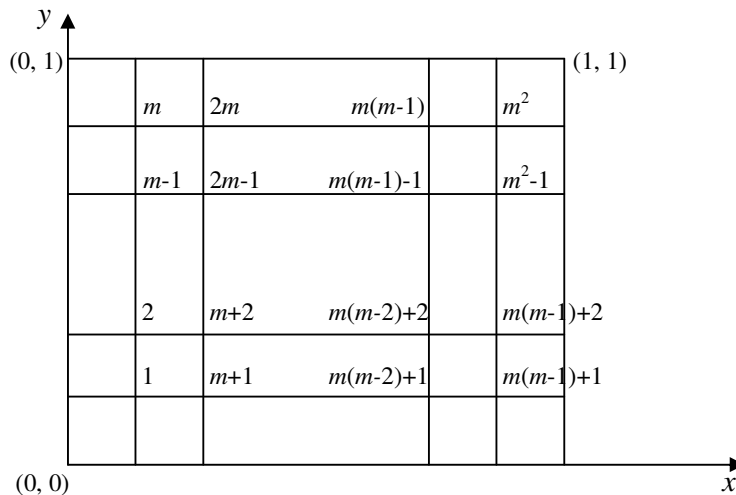

Figure 1

The standard technique for solving the sparse linear systems derived from the discretisation of self-adjoint elliptic partial differential equations by finite difference techniques (block or line iterative methods) can be improved if we use explicit group methods (Evans and Biggins, 1982), (Yousif & Evans, 1986). These explicit groups are obtained using the standard five point finite difference formula.

In this paper we approximate the solution of the equation (1.4) by using coordinates rotated 45° with respect to the mesh (Dahlquist and Bjorck, 1974), (Vichnevetsky, 1981). The spacing between points becomes $\sqrt{2}h$, then at each grid point, the discretised form of equation (1.4) is

$$u_{i+1,j+1} + u_{i-1,j-1} - 4u_{i,j} + u_{i+1,j-1} + u_{i-1,j+1} = 0. \quad (1.5)$$

The discretisation of (1.4) leads to (1.1), (Varga, 1962). Thus, let us consider

$$A = D - E - F \quad (1.6)$$

where $D = \text{diag}(A)$, E and F are strictly lower and upper triangular matrices obtained from A , respectively.

The AOR iterative method is given by:

$$(D - rE)u^{(k+1)} = [(1 - \omega)D + (\omega - r)E + \omega F]u^{(k)} + \omega b, \quad k = 0, 1, \dots \quad (1.7)$$

where ω, r are real parameters and $\omega \neq 0$.

If we define $L = D^{-1}E$ and $U = D^{-1}F$ then the equation (1.7) takes the form

$$u^{(k+1)} = L_{r,\omega}u^{(k)} + \omega(D - rE)^{-1}b, \quad k = 0, 1, \dots \quad (1.8)$$

where

$$L_{r,\omega} = (I - rL)^{-1} [(1 - \omega)I + (\omega - r)L + \omega U] . \quad (1.9)$$

As we mentioned before, some well-known iterative methods can be obtained from (1.7) with a suitable choice of values for ω and r . Therefore, if we consider $\omega = r$ we have the Successive Overrelaxation method (SOR), but if we take $\omega = 1$ and $r = 0$ we have the Jacobi method (J). Obviously if we consider $\omega = r = 1$ we have the Gauss-Seidel (GS) method and the Simultaneous Overrelaxation method (JOR) can be obtained if $r = 0$ and ω takes any value.

A brief description of the 4-point EGAOR iterative method is given in Sections 2 then the 4-point EDGAOR method is presented in Section 3. In order to show the performance of the two methods and to investigate their behaviour, numerical experiments have been carried out and the results are summarised in Section 4. The computational complexity and the relative efficiency of the two methods are discussed in Section 5. A comparison between the two method is made when we approximate the solution of the model problem which shows that the new method is computationally more economic and much faster than the group AOR method.

**2. THE 4-POINT EXPLICIT GROUP ACCELERATED
OVERRELAXATION
(EGAOR) ITERATIVE METHOD**

In this section we will briefly show the derivation of the 4-point (EGAOR) iterative method. We assume that the mesh points of Figure 1 are ordered in groups of four in accordance with Figure 2, where $t = (pm+1)$, step 2, $(p+1)m-1$, m is an even number and $p = 0$, step 2, $m-2$. Each group G_l , $l = 1, 2, \dots, m^2/4$ contains only four elements $\{t, t+1, t+m, t+m+1\}$.

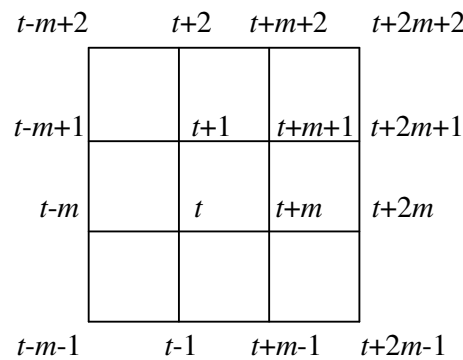

Figure 2

Then the linear system obtained from employing the five-point difference formula to the four adjacent points, i.e., $u_t, u_{t+1}, u_{t+m}, u_{t+m+1}$, simultaneously, can be expressed in matrix vector notation as

$$\begin{bmatrix} 4 & -1 & -1 & 0 \\ -1 & 4 & 0 & -1 \\ -1 & 0 & 4 & -1 \\ 0 & -1 & -1 & 4 \end{bmatrix} \begin{bmatrix} u_t \\ u_{t+m} \\ u_{t+1} \\ u_{t+m+1} \end{bmatrix} = \begin{bmatrix} u_{t-1} + u_{t-m} \\ u_{t+m-1} + u_{t+2m} \\ u_{t-m+1} + u_{t+2} \\ u_{t+m+2} + u_{t+2m+1} \end{bmatrix} \tag{2.1}$$

Now the explicit solution of this system is

$$\begin{bmatrix} u_t \\ u_{t+m} \\ u_{t+1} \\ u_{t+m+1} \end{bmatrix} = \frac{1}{24} \begin{bmatrix} 7 & 2 & 2 & 1 \\ 2 & 7 & 1 & 2 \\ 2 & 1 & 7 & 2 \\ 1 & 2 & 2 & 7 \end{bmatrix} \begin{bmatrix} u_{t-1} + u_{t-m} \\ u_{t+m-1} + u_{t+2m} \\ u_{t-m+1} + u_{t+2} \\ u_{t+m+2} + u_{t+2m+1} \end{bmatrix} \tag{2.2}$$

By using the system (2.2), we can derive the 4-point explicit group AOR iterative method:

$$\begin{aligned}
u_t^{(k+1)} = & \frac{1}{24} \left\{ 7 \left[\omega(u_{t-m}^{(k)} + u_{t-1}^{(k)}) + r(u_{t-m}^{(k+1)} + u_{t-1}^{(k+1)} - u_{t-m}^{(k)} - u_{t-1}^{(k)}) \right] \right. \\
& + 2 \left[\omega(u_{t+m-1}^{(k)} + u_{t-m+1}^{(k)} + u_{t+2m}^{(k)} + u_{t+2}^{(k)}) + r(u_{t+m-1}^{(k+1)} + u_{t-m+1}^{(k+1)} - u_{t+m-1}^{(k)} - u_{t-m+1}^{(k)}) \right] \\
& \left. + \omega(u_{t+2m+1}^{(k)} + u_{t+m+2}^{(k)}) \right\} + (1 - \omega)u_t^{(k)}
\end{aligned} \tag{2.3a}$$

$$\begin{aligned}
u_{t+1}^{(k+1)} = & \frac{1}{24} \left\{ 7 \left[\omega(u_{t-m+1}^{(k)} + u_{t+2}^{(k)}) + r(u_{t-m+1}^{(k+1)} - u_{t-m+1}^{(k)}) \right] \right. \\
& + 2 \left[\omega(u_{t-m}^{(k)} + u_{t-1}^{(k)} + u_{t+2m+1}^{(k)} + u_{t+m+2}^{(k)}) + r(u_{t-m}^{(k+1)} + u_{t-1}^{(k+1)} - u_{t-m}^{(k)} - u_{t-1}^{(k)}) \right] \\
& \left. + \omega(u_{t+m-1}^{(k)} + u_{t+2m}^{(k)}) + r(u_{t+m-1}^{(k+1)} - u_{t+m-1}^{(k)}) \right\} + (1 - \omega)u_{t+1}^{(k)}
\end{aligned} \tag{2.3b}$$

$$\begin{aligned}
u_{t+m}^{(k+1)} = & \frac{1}{24} \left\{ 7 \left[\omega(u_{t+m-1}^{(k)} + u_{t+2m}^{(k)}) + r(u_{t+m-1}^{(k+1)} - u_{t+m-1}^{(k)}) \right] \right. \\
& + 2 \left[\omega(u_{t-m}^{(k)} + u_{t-1}^{(k)} + u_{t+2m+1}^{(k)} + u_{t+m+2}^{(k)}) + r(u_{t-m}^{(k+1)} + u_{t-1}^{(k+1)} - u_{t-m}^{(k)} - u_{t-1}^{(k)}) \right] \\
& \left. + \omega(u_{t-m+1}^{(k)} + u_{t+2}^{(k)}) + r(u_{t-m+1}^{(k+1)} - u_{t-m+1}^{(k)}) \right\} + (1 - \omega)u_{t+m}^{(k)}
\end{aligned} \tag{2.3c}$$

$$\begin{aligned}
u_{t+m+1}^{(k+1)} = & \frac{1}{24} \left\{ 7 \left[\omega(u_{t+2m+1}^{(k)} + u_{t+m+2}^{(k)}) \right] \right. \\
& + 2 \left[\omega(u_{t+m-1}^{(k)} + u_{t-m+1}^{(k)} + u_{t+2m}^{(k)} + u_{t+2}^{(k)}) + r(u_{t+m-1}^{(k+1)} + u_{t-m+1}^{(k+1)} - u_{t+m-1}^{(k)} - u_{t-m+1}^{(k)}) \right] \\
& \left. + \omega(u_{t-m}^{(k)} + u_{t-1}^{(k)}) + r(u_{t-m}^{(k+1)} + u_{t-1}^{(k+1)} - u_{t-m}^{(k)} - u_{t-1}^{(k)}) \right\} + (1 - \omega)u_{t+m+1}^{(k)}
\end{aligned} \tag{2.3d}$$

where $t = (pm + 1)$, step 2, $(p + 1)m - 1$ and $p = 0$, step 2, $m-2$.

As we stated in section 1, the Jacobi, Gauss-Seidel, SOR and JOR methods are special cases of the AOR iterative method.

Therefore, in equations (2.3), if we consider $\omega = r$, $\omega = r = 1$, $r = 0$ and $\omega = 1$, and

$r = 0$ and ω taking any value, we obtain the explicit group SOR, Gauss-Seidel, Jacobi and JOR methods, respectively. Thus, obviously, equation (2.15) in (Yousif & Evans, 1986) , can be obtained from (2.3) if we let $r = 0$ and $\omega = 1$.

3. THE 4-POINT EXPLICIT DECOUPLED GROUP ACCELERATED OVERRELAXATION (EDGAOR) ITERATIVE METHOD

In this section we will present an explicit set of equations for the 4-point EDGAOR iterative method, where each group is formed from 4 points of the net region Figure 1 in accordance with Figure 2, where t , m , p and G_t are defined in Section 2.

If we use the rotated five-point approximation scheme, this will result in a (4×4) system of equations

$$\begin{bmatrix} 4 & -1 & 0 & 0 \\ -1 & 4 & 0 & 0 \\ 0 & 0 & 4 & -1 \\ 0 & 0 & -1 & 4 \end{bmatrix} \begin{bmatrix} u_t \\ u_{t+m+1} \\ u_{t+m} \\ u_{t+1} \end{bmatrix} = \begin{bmatrix} u_{t+m-1} + u_{t-m+1} + u_{t-m-1} \\ u_{t+2m} + u_{t+2m+2} + u_{t+2} \\ u_{t+2m-1} + u_{t+2m+1} + u_{t-1} \\ u_{t+m+2} + u_{t-m+2} + u_{t-m} \end{bmatrix} \quad (3.1)$$

The explicit solution of this system can be de-coupled into the following system of two (2x2) equations (see Abdullah (1991))

$$\begin{bmatrix} u_t \\ u_{t+m+1} \end{bmatrix} = \frac{1}{15} \begin{bmatrix} 4 & 1 \\ 1 & 4 \end{bmatrix} \begin{bmatrix} u_{t+m-1} + u_{t-m+1} + u_{t-m-1} \\ u_{t+2m} + u_{t+2m+2} + u_{t+2} \end{bmatrix} \quad (3.2)$$

and

$$\begin{bmatrix} u_{t+m} \\ u_{t+1} \end{bmatrix} = \frac{1}{15} \begin{bmatrix} 4 & 1 \\ 1 & 4 \end{bmatrix} \begin{bmatrix} u_{t+2m-1} + u_{t+2m+1} + u_{t-1} \\ u_{t+m+2} + u_{t-m+2} + u_{t-m} \end{bmatrix} \quad (3.3)$$

Figure 3 and Figure 4 shows the position of the computational molecule at the points t and $t+1$, respectively. Let us notice that the points (points of type \bigcirc) used in the calculation of \mathbf{u} at the nodal points t and $t+m+1$ are independent from the points (points of type \square) used in the evaluation of the function values at the points $t+m$ and $t+1$.

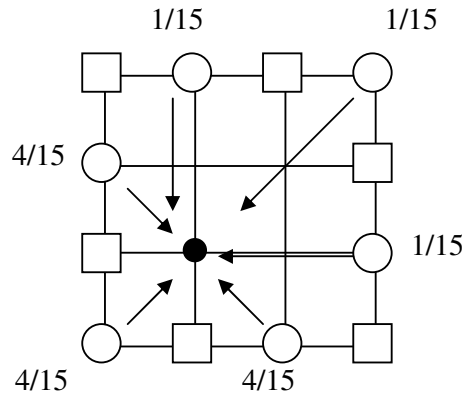

Figure 3 The computational molecule at the point u_t

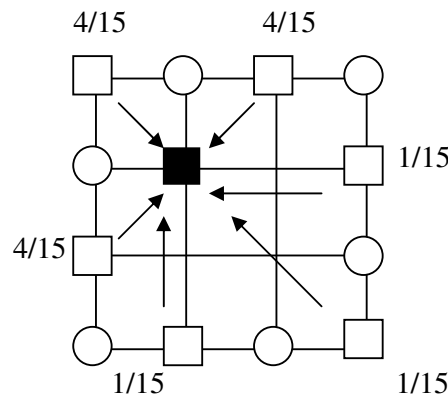

Figure 4 The computational molecule at the point u_{t+1}

Due to this independency, the execution time can be saved by nearly half if the iteration over the solution domain is only carried out on either type of points. After achieving convergence, the solution at the other half of the points is obtained directly once using the standard five point difference formula.

Therefore we can derive the 4-point EDGAOR method, the iterative scheme is given by:

$$u_t^{(k+1)} = \frac{1}{15} [4(\omega - r)(u_{t+m-1}^{(k)} + u_{t-m+1}^{(k)} + u_{t-m-1}^{(k)}) + 4r(u_{t+m-1}^{(k+1)} + u_{t-m+1}^{(k+1)} + u_{t-m-1}^{(k+1)}) + \omega(u_{t+2m}^{(k)} + u_{t+2m+2}^{(k)} + u_{t+2}^{(k)})] + (1 - \omega)u_t^{(k)} \quad (3.4a)$$

$$u_{t+m+1}^{(k+1)} = \frac{1}{15} [(\omega - r)(u_{t+m-1}^{(k)} + u_{t-m+1}^{(k)} + u_{t-m-1}^{(k)}) + r(u_{t+m-1}^{(k+1)} + u_{t-m+1}^{(k+1)} + u_{t-m-1}^{(k+1)}) + 4\omega(u_{t+2m}^{(k)} + u_{t+2m+2}^{(k)} + u_{t+2}^{(k)})] + (1 - \omega)u_{t+m+1}^{(k)} \quad (3.4b)$$

or

$$u_{t+m}^{(k+1)} = \frac{1}{15} [4\omega(u_{t-1}^{(k)} + u_{t+2m-1}^{(k)} + u_{t+2m+1}^{(k)}) + 4r(u_{t-1}^{(k+1)} + u_{t+2m-1}^{(k+1)} - u_{t-1}^{(k)} - u_{t+2m-1}^{(k)}) + \omega(u_{t+m+2}^{(k)} + u_{t-m+2}^{(k)} + u_{t-m}^{(k)}) + r(u_{t-m+2}^{(k+1)} + u_{t-m}^{(k+1)} - u_{t-m+2}^{(k)} - u_{t-m}^{(k)})] + (1 - \omega)u_{t+m}^{(k)} \quad (3.5a)$$

$$u_{t+1}^{(k+1)} = \frac{1}{15} [\omega(u_{t-1}^{(k)} + u_{t+2m-1}^{(k)} + u_{t+2m+1}^{(k)}) + r(u_{t-1}^{(k+1)} + u_{t+2m-1}^{(k+1)} - u_{t-1}^{(k)} - u_{t+2m-1}^{(k)}) + 4\omega(u_{t+m+2}^{(k)} + u_{t-m+2}^{(k)} + u_{t-m}^{(k)}) + 4r(u_{t-m+2}^{(k+1)} + u_{t-m}^{(k+1)} - u_{t-m+2}^{(k)} - u_{t-m}^{(k)})] + (1 - \omega)u_{t+1}^{(k)} \quad (3.5b)$$

where $t = (pm + 1)$, step 2, $(p + 1)m - 1$ and $p = 0$, step 2, $m-2$.

Hence, the iterations to approximate the solution in all domain is only carried out on half the mesh points, using equations (3.4) or (3.5). Once convergence is achieved, the solution at the other half of the mesh is evaluated once using the standard five point difference formula.

4. NUMERICAL RESULTS

In this section we present some numerical examples in order to compare the 4-point EGAOR and the 4-point EDGAOR iterative methods. These methods were applied to Laplace's equation,

$$\frac{\partial^2 U}{\partial x^2} + \frac{\partial^2 U}{\partial y^2} = 0 \quad x, y \in \Omega = (0, 1) \times (0, 1) \quad (4.1)$$

and the Dirichlet boundary conditions

$$\begin{aligned} U(x,0) &= \sin \pi x, & 0 \leq x \leq 1, \\ U(0,y) = U(1,y) = U(x,1) &= 0, & 0 \leq x, y \leq 1 \end{aligned} \quad (4.2)$$

The coefficient matrix for the two methods possesses Property $A^{(\pi)}$ and are π -consistently ordered (see Young, 1971). Therefore the theory of block AOR is valid and consequently the algorithms can be used with parameters ω and r ($\omega \neq 0$). In some special cases the optimal values ω and r can be obtained from Theorem 5.2 of (Hadjidimos, 2000). In this example, the used values ω and r were obtained computationally starting with r very close to the optimal parameter of the SOR method.

The convergence test used in the numerical experiments was the average test with the maximum error $\epsilon = 5 \times 10^{-6}$.

Table 1: r , ω , and number of iterations for the 4-point GAOR method

h^{-1}	r	ω	No. of Iterations
11	1.452	1.42 – 1.43	17
21	1.66	1.60 – 1.66	34
31	1.76	1.613	48
41	1.81	1.74 – 1.75	64
61	1.866	1.816 – 1.818	94
81	1.897	1.815 – 1.824	125
101	1.917	1.851 – 1.852	155

Table 2: r , ω , and number of iterations for the 4-point EDGAOR method

h^{-1}	r	ω	No. of Iterations
11	1.41	1.39 – 1.41	15
21	1.63	1.55 – 1.64	29
31	1.735	1.69 – 1.72	39
41	1.794	1.68 – 1.72	48
61	1.857	1.738 – 1.75	71
81	1.89	1.792 – 1.842	93
101	1.911	1.812 – 1.849	114

For self adjoint equations, the 4-point group coefficients can be stored in tabular form and then easily accessed for future iterations.

5. ANALYSIS OF THE COMPUTATIONAL COMPLEXITY OF THE 4-POINT EDGAOR METHODS

The computational effort measured by the number of operations needed to obtain an approximation of the solution of (1.1) using the 4-point EDGAOR method presented in Section 3 will be discussed. We assume that a multiplication takes the same computer time as an addition.

In equation (3.4), let $b = 1/15$, $w_1 = 1 - \omega$, $w_2 = b \times (\omega - r)$, $w_3 = b \times r$, $w_4 = b \times \omega$ these need only be calculated once.

Thus if we set

$$\begin{aligned} s_1 &= w_2 \times (u_{t+m-1}^{(k)} + u_{t-m+1}^{(k)} + u_{t-m-1}^{(k)}), & s_2 &= w_3 \times (u_{t+m-1}^{(k+1)} + u_{t-m+1}^{(k+1)} + u_{t-m-1}^{(k+1)}), \\ s_3 &= w_4 \times (u_{t+2m}^{(k)} + u_{t+2m+2}^{(k)} + u_{t+2}^{(k)}), \end{aligned} \quad (5.1)$$

and $s_4 = s_1 + s_2$,

then we have

$$\begin{aligned} u_t^{(k+1)} &= (4 \times s_4) + s_3 + w_1 \times u_t^{(k)}, \\ u_{t+m+1}^{(k+1)} &= s_4 + (4 \times s_3) + w_1 \times u_{t+m+1}^{(k)}. \end{aligned} \quad (5.2)$$

It can be seen that the number of operations required (excluding the convergence test) for the 4-point EDGAOR method is

$$4.5 m^2 \text{ operations per iteration} + 2.5 m^2 \text{ operations.} \quad (5.3)$$

while the number of operations required (excluding the convergence test) for the 4-point EGAOR method (Martins, Yousif and Evans, 2002) is

$$11.75 m^2 \text{ operations per iteration.} \quad (5.4)$$

Hence, the total computing effort can be determined by multiplying the values of the calculated number of iterations for the two methods (see Tables 1 and 2) by the number of arithmetic operations in each iteration required by each of the methods, these are presented in Table 3.

For the self adjoint case, 50% extra work is required for the 4-point EGAOR and the 4-point EDGAOR methods.

Table 3: The computing effort for the two methods

h^{-1}	4-Point EGAOR	4-Point EDGAOR
11	199.75 m^2	70 m^2
21	399.50 m^2	133 m^2
31	564.00 m^2	178 m^2
41	752.00 m^2	218.5 m^2
61	1104.50 m^2	322 m^2
81	1468.75 m^2	421 m^2
101	1821.25 m^2	515.5 m^2

6. CONCLUSIONS

From our analysis of the computational complexity of the two methods (i.e. Equations (5.3) and (5.4)), it can be seen that the 4-point EDGAOR method enable more efficient manipulation of the algorithm by reducing the number of operations required to solve the problem. Further, the results given in Tables 1 and 2 together with the results shown in Table 3, indicates that the 4-point EDGAOR method should offer significant economies over the 4-point EGAOR method as a substantial reduction in the total computing effort was achieved.

ACKNOWLEDGEMENT

This work was supported by Instituto de Telecomunicações de Coimbra.

REFERENCES

1. Abdullah, A. R., (1991). The four point explicit decoupled group (EDG) method: A fast Poisson solver, *Intern. J. Computer Math.*, v 38, pp 61-70.
2. Dahlquist, G., and Bjorck, A., (1974). *Numerical Methods*, Englewood Cliffs, NJ: Prentice-Hall.
3. Evans, D. J., and Biggins, M. J., (1982). The solution of elliptic partial differential equations by a new block overrelaxation technique, *Intern. J. Computer Math.*, v. 28, pp. 269-282.
4. Hadjidimos, A., (1978). Accelerated overrelaxation method, *Math. Comp.*, v. 32, pp. 149-157.
5. Hadjidimos, A., (2000). Successive overrelaxation (SOR) and related methods, *Jour. Comp. and Appl. Math.*, v. 123, pp. 177- 199.

6. Martins M. M., Yousif, W. S., and Evans, D. J., (2002). Explicit group AOR method for solving elliptic partial differential equations, *Neural, Parallel & Scientific Computations*, v. 10. pp. 411-422.
7. Varga, R. S. (1962). *Matrix iterative analysis*, Englewood Cliffs, NJ: Prentice-Hall.
8. Vichnevetsky, R., (1981). *Computer Methods for partial differential equations*, Volume 1, Englewood Cliffs, NJ: Prentice-Hall.
9. Yousif, W. S., & Evans, D. J., (1986). Explicit group over-relaxation methods for solving elliptic partial differential equations, *Maths and Computers in Simulation*, v. 28. pp. 453-466.
10. Young, D. (1971). *Iterative solutions for large linear systems*, Academic Press, New York.